



MEDIUM CAPACITY, 50HZ, ELECTRIC HYDRAULIC PUMPS

**VEKTEK LLC
1334 EAST AVENUE
EMPORIA, KS 66801
+1-913-365-1045
www.vektek.com**

Also included Machine to Pump Control Wiring Instructions, IS-7074



VektorFlo® is a registered trademark of Vektek LLC

Vektek LLC reserves the right to change specifications without notice in an ongoing product improvement process.

Vektek LLC
1334 East Sixth Street
Emporia, KS 66801
+1-913-365-1045
sales@vektek.com
www.vektek.com

PUMP MODEL # _____ -- _____ -- _____

PUMP SERIAL # _____

IN SERVICE DATE _____

TABLE OF CONTENTS

	<u>Page</u>
Preliminary and Safety Information (Section I).....	4
Hydraulic Fluid (Section II).....	7
Pump Installation (Section III).....	8
A. Specifications	
B. Set-up	
C. Air Bleeding	
Control Valves (Section IV).....	12
Maintenance (Section V).....	13
A. Intervals	
B. Parts List	
C. Wiring Diagram	
Trouble Shooting (Section VI).....	47
Warranty and Return Information (Section VII).....	49
Hydraulic Fluid MSDS (Section VIII).....	50

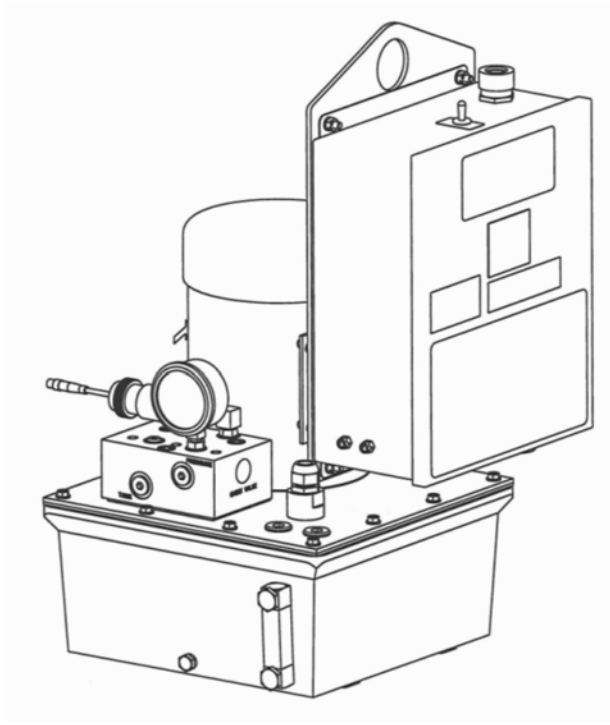

SECTION I

PRELIMINARY AND SAFETY INFORMATION

FAILURE TO HEED THE FOLLOWING INFORMATION WILL VOID WARRANTY

Preliminary Information

Most malfunctions in new equipment are the result of improper set-up and operation. Please read and fully understand the entire enclosed information.

Remove the pump from the shipping container. **DO NOT** remove plugs or valves until unit is ready to be installed to prevent any foreign matter from contaminating the system.

Visually inspect all components for shipping damage and correct configuration. Report any damage found to the carrier or factory immediately.

Compare motor data plate with power availability. Power supply must be of the same rating or equipment damage may occur. Connect the pump to the power source per wiring diagram in section V.

This pump is equipped with BSPP type ports for all external hydraulic connections. With this type of connection, **DO NOT** use pipe dope, thread sealing tape, or other materials. Such materials may contaminate the hydraulic system and damage the sealing surfaces of the valves. Detection of such materials will void the pump warranty.

This pump is equipped with an electric switch that shuts the pump motor off when it reaches a preset pressure. The motor will automatically restart if the system pressure falls by approximately 5% of pressure setting. The pump also includes an electric fluid level switch that will shut the pump motor off if the fluid level is too low.

When connected to a properly functioning clamping system, the hydraulic pressure may bleed down very slowly after the pump motor stops. Depending upon the size and complexity of the system, the motor should restart only once every five to ten minutes, after the system is fully pressurized.

SECTION I

PRELIMINARY AND SAFETY INFORMATION (continued)

Safety

1.0 Working Pressure

The maximum pump working pressure is 350 BAR. Make sure that all hydraulic equipment used with this pump is rated at 350 BAR working pressure.

WARNING

Failure to use such rated equipment may result in system failure, property damage, or bodily injury.

2.0 Hydraulic Connections

Threaded connections such as fittings must be securely tightened. Quick disconnect couplings must be securely engaged and undamaged. **NEVER** disconnect or connect any hydraulic fittings under pressure.

WARNING

Loose or improperly threaded fittings can pose a potential safety hazard. **NEVER** touch or contact a hydraulic leak in any way. Failure to follow this warning may result in escaping high pressure fluid penetrating the skin and causing serious bodily injury.

3.0 Electrical Power

- A. Check for proper electrical supply before connecting power.
- B. If using an extension cord, be certain that it is properly sized for the current load, see section III.
- C. **DO NOT** use a power cord that is damaged.
- D. **DO NOT** use an ungrounded extension cord or power outlet, as the motor must be grounded.
- E. Pump is equipped with a Totally Enclosed Fan Cooled (TFEC) motor. It is not explosion proof and may spark.
- F. **DO NOT** operate in an explosive atmosphere or in the presence of combustible or conductive liquids.

WARNING

Failure to follow this information may cause an explosion resulting in property damage or bodily injury.

SECTION I

PRELIMINARY AND SAFETY INFORMATION (continued)

4.0 Operating Safely

WARNING

DO NOT connects or disconnect from the pump while under pressure. First turn the pump motor off. Then slowly shift the valve through all positions to completely depressurize the system. Check gage(s) to verify that all system pressure has been relieved.

Keep the operator thinking. Set and enforce work rules that help avoid property or bodily injury. Make certain all operators are properly trained.

SECTION II

HYDRAULIC FLUID

VektorFlo[®] hydraulic oil, p/n 65-0010-01 (one gallon), is recommended for all Vektek pumps operating in ambient temperatures above -15°C (5°F).

VektorFlo[®] hydraulic oil is a premium grade petroleum based fluid with detergent and anti-wear additives. VektorFlo[®] hydraulic oil also includes additives to inhibit corrosion, rust, oxidation, and foaming.

VektorFlo[®] Hydraulic Oil Characteristics:

Pour Point.....	<-15°C (5°F)
Flash Point.....	>150°C (302°F) (PMCC)
Viscosity	22-320 cSt @ 40°C (104°F)
.....	4-24 cSt @ 100°C (212°F)
ISO Viscosity Grade.....	32

You may also substitute other brands of oil rated at ISO grade 32. Vektek recommends completely draining existing oil before any substitution is made.

Use of hydraulic oil with a viscosity grade higher than ISO 32 may cause sluggish return action of single acting devices and should therefore, only be used on double acting systems. ISO grade 46 is compatible with Vektek pumps and may be used if deemed necessary.

MSDS sheet, see section VIII.

SECTION III

PUMP INSTALLATION

A. Specifications

Voltage (VAC)	Phase (PH)	Current (A)	Cycles (Hz)	RPM	Rotation*
230	3	3.4	50	2850	Clockwise
380	3	2	50	2850	Clockwise
440	3	1.7	50	2850	Clockwise

* Looking at fan side of motor.

Pump Motor Voltage	Holding Current	Approx. Inrush Current	Minimum Voltage at Motor*	Current Drawn Per Valve
230V	5A	27A	207V	See Valve Section
380V	3A	15.5A	342V	See Valve Section
440V	1.7A	13.5A	396V	See Valve Section

*Voltage measured at full load

Valves	71-1122-54 71-1150-03	71-1122-13 71-1150-05	71-1235-21	71-1235-22	71-1235-40	71-1235-41
Current	1.2A	0.3A	1.2A	0.2A	1.2A	0.3A
Approx. Inrush	1.3A	0.4A	1.3A	0.3A	1.3A	0.4A

1. Flow Rate
 - a. Low Pressure..... 5.3 L/min @ 45 BAR
 - b. High Pressure..... 0.66 L/min @ 350 BAR

2. Maximum Operating Pressure..... 350BAR

3. Fluid Capacity
 - a. Nominal..... 8.2 Liters
 - b. Useable..... 6.6 Liters

4. Safety Overpressure Relief.....Integral to Manifold

5. Filtration
 - a. Integral Pump Suction Screen.....100 micron
 - b. Integral Manifold Sintered Bronze.....25 micron

6. Pressure Switch
 - a. Contacts.....Normally Closed
 - b. Rating.....1 A @ 24VAC

7. Fluid Level Sensor
 - a. Contacts.....Normally Closed
 - b. Rating.....1 A @ 24VAC

8. Motor Contactor.....	24VAC
9. Duty Cycle.....	50%
10. Hydraulic Connections.....	BSPP

SECTION III

PUMP INSTALLATION (continued)

B. Set-up

BEFORE turning the pump on, fill reservoir with iso grade hydraulic fluid.

Check the hydraulic oil level on the external sight glass. With all cylinders retracted and the pump motor off, the oil level should be approximately 13mm below the reservoir top plate. If unsure of the oil level, verify the oil level by opening the reservoir fill plug located on the reservoir top plate. Add oil, as necessary.

Verify that all desired gage, valve, hose, and quick coupler connections are tightened properly before operating. The pump is equipped with BSPP connections located on the front surface of the manifold block or on the ends of the valve blocks, depending on the model number. Use **ONLY** BSPP style fittings to connect to these ports.

Momentarily bump the power switch to “jog” to check for the proper rotation of the electric motor. The motor should rotate in the direction of the arrow on the motor.

When the electric system is on, and the system is pressurized, the motor will shut-off at the pressure set by the factory, normally approximately 350 BAR. The pressure is controlled by the adjustable system pressure switch.

During the initial set-up of any new system, it recommended that the pressure switch be set to the minimum pressure required to operate the system components. Cycling the system at low pressure should reveal most oversights in the installation such as stroke, interference, loose fitting connections, and clamp positioning. After checking the system at low pressure, re-set the pressure switch, as described below, to operate the system at the desired pressure.

Pressure Switch Adjustment

- A. Pump must be connected to a fixture or other device, rated at 350 BAR, that requires fluid volume in order to set the pressure switch.
- B. Turn the pump on, position the control valve to the clamp position, and note the gage reading at which the pump shuts off.
- C. To change the pressure switch set point, rotate the red adjuster ring on the pressure switch in the direction indicated on the pressure switch in ¼ turn increments. Repeat until the desired pressure is reached. NEVER attempt to adjust the pressure switch setting to more that 350 BAR (range: 55-350 BAR).

SECTION III

PUMP INSTALLATION (continued)

NOTICE

The pressure switch supplied with the pump is for the control of motor function only. It is not intended to interface with machine controllers or to be used for process control. If a pressure switch is required for process control, it is recommended that a separate switch be installed down stream from the control valves or that a Vektek Pallet Pressure Monitor system be used. When the switch shuts off the motor, the motor will continue to rotate, coasting to a stop. During this time, the pump will continue to build pressure slightly. This is classified, as “over-run” and a pressure setting adjustment may be necessary to compensate for the over-run condition. This condition may be more noticeable in small or tight circuits.

C. Bleeding Air From The System

Sluggish or jerky device action is usually an indication of air in the system. Accordingly, remove as much air from the system as possible using the following procedures.

Bleeding air from the hydraulic system can be a tedious task. The following suggestions should help.

Air naturally moves toward the highest point in the circuit or device. Elevating the pump to a height greater than the fixture and cycling the control valves several times will usually evacuate most of the air.

If the system proves to be particularly difficult to bleed, install a bleeder in the system or perform the following procedure. Starting at a connection that is either farthest from the pump, or highest in the system, carefully loosen (crack) a fitting enough to allow a small stream of oil to escape. **DO NOT** fully remove fitting under hydraulic pressure as bodily injury may occur. The appearance of “milky” oil indicates that air is being evacuated from the system. When the oil is clear, retighten the fitting and check for normal system operation. Repeat this procedure with subsequent fittings closer to the pump, or lower in the system.

WARNING

NEVER touch or contact a hydraulic leak in any way. Failure to follow this warning may result in escaping high pressure fluid penetrating the skin and causing serious bodily injury.

SECTION IV

CONTROL VALVES

When starting any pump, caution should be taken to avoid sudden or undesired system movement. Move handles on manual valves and pendant switches to the appropriate position.

CAUTION

On manual valves, if the handle is not fully engaged in a detent position, the clamps may move but full clamping force may not be achieved. Always make sure that the handles are completely adjusted to the desired position.

SECTION V

MAINTENANCE

WARNING

Disconnect electric power to the pump **BEFORE** performing any maintenance. **DO NOT** connect or disconnect from the pump while under pressure. First turn the pump motor off. Then slowly shift the valve through all positions to completely depressurize the system. Check gage(s) to verify that all system pressure has been relieved. Failure to follow this warning may result in property damage or bodily injury.

CAUTION

ALWAYS clean dirt and other contaminants from the pump before any maintenance is performed to prevent contamination from entering the system.

CAUTION

NEVER mix different grades of oil. Completely drain and flush system of oil and refill with new grade if deemed necessary.

A. Intervals

1.0 Daily

- a. Check oil level. Oil should be approximately 13mm below the top plate of the reservoir with all devices retracted.
- b. Check hoses, tubing, fittings, and quick couplers for damage and wear. Replace as necessary.
- c. Check for damaged electrical connectors and cords. **DO NOT** operate the pump if damage is found.
- d. Check and replace the Return-Line Filter 31-0500-14 as soon as the needle of the Filter Indicator Gauge 72-0021-00 reads in the “Red Change” area of the gauge during the return cycle of the pump.

IMPORTANT: Failure to service the Return-Line Filter when initially indicated by the Filter Indicator Gauge will result in a non-warranty failure of this gauge.

2.0 Monthly

- a. Remove and clean the bronze full flow filter, Vektek p/n 31-0910-05, see parts list for location. Clean the filter from the inside out using a non-flammable solvent and drying with air. Make sure the o-ring is in the proper place when re-assembling. Torque the spring retainer per note. If the filter shows signs of wear, stress, fracture, or cannot be satisfactorily cleaned, replace with a new filter.

WARNING

DO NOT operate the pump with out the filter installed. Damage may result and will void warranty.

- b. Wipe the pump off to keep it clean. Dirt and grime accumulation contribute to overheating of the motor and oil.

SECTION V

MAINTENANCE (continued)

3.0 Every 6 Months

- a. Change oil.
 - i. Drain the oil using the reservoir drain plug.
 - ii. Remove the motor pump assembly from the reservoir by removing the top plate bolts.
 - iii. Remove the suction screen from the bottom of the pump. Clean with a non-flammable solvent and air. Reinstall the suction screen.
 - iv. Reassemble the motor pump assembly to the reservoir.
 - v. Refill the reservoir with the correct grade of oil to approximately 13mm below the top plate with devices retracted.

If system contamination is suspected, drain, clean, and refill the reservoir as described above. Operate the pump in a no load condition for a maximum of one minute. Then drain and refill the reservoir. Check for normal operation.

SECTION V

MAINTENANCE (continued)

B. Parts List

PUMP ASSEMBLY DETAIL A

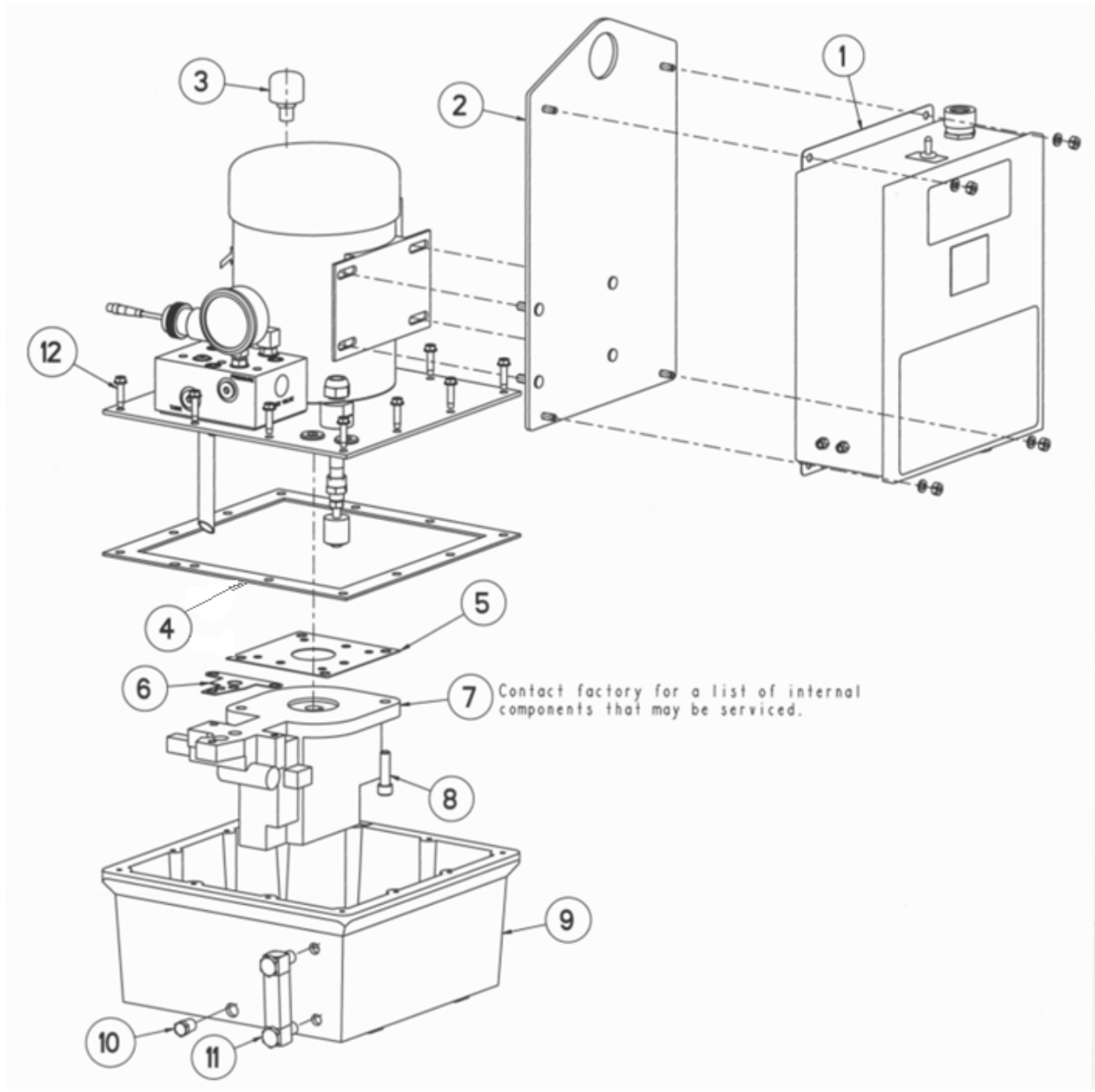

SECTION V

MAINTENANCE (continued)
PUMP ASSEMBLY DETAIL A

ITEM NO.	PART NO.	DESCRIPTION
1	94559203	0 VALVE 220/380/440VAC COMPLETE ELECTRICAL CONTROL BOX*
	94559204	2 VALVE 220/380/440VAC COMPLETE ELECTRICAL CONTROL BOX*
	94559205	4 VALVE 220/380/440VAC COMPLETE ELECTRICAL COMTROL BOX*
		*NOTE: REQUIRES THERMAL OVERLOAD PACK:
		P/N 28731132 – 230/380VAC
		P/N 28731148 - 440VAC
2	95534213	PUMP LIFT PLATE
3	85594409	RESERVOIR BREATHER/FILTER
4	85594410	RESERVOIR GASKET
5	85594407	PUMP HEAD GASKET
6	85594406	PUMP TAIL GASKET
7	85534292	PUMP UNIT
8	21411024	SOCKET HEAD CAPSCREW, 3/8-16 UNC-2A X 1 3/8
9	85594400	RESERVOIR
10	30603600	PLUG, 1/4-18 NPT
11	85534276	FLUID LEVEL SIGHT GAGE
12	21410065	SELF-TAPPING SCREW, 1/4-20 UNC-2A

NOTES: _____

SECTION V

MAINTENANCE (continued)
PUMP ASSEMBLY DETAIL B

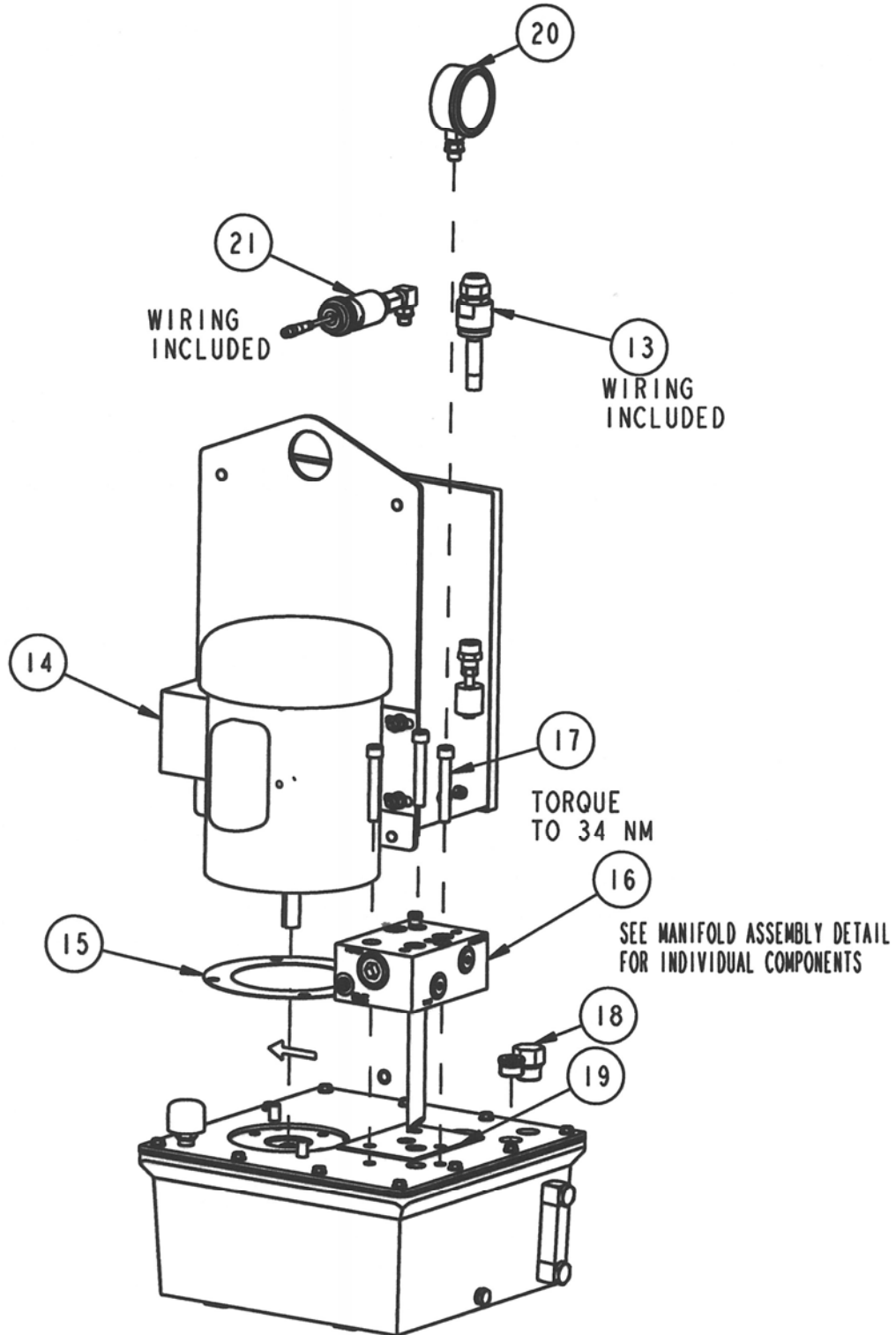

SECTION V

MAINTENANCE (continued)
PUMP ASSEMBLY DETAIL B

ITEM NO.	PART NO.	DESCRIPTION
13	95534226	FLUID LEVEL SENSOR ASSEMBLY - INCLUDES ALL WIRING
14	84559201	ELECTRIC MOTOR, 220/380/440VAC 50 HZ
15	85594402	MOTOR GASKET
16	93107202	MANIFOLD ASSEMBLY - COMPLETE
17	21411020	SOCKET HEAD CAPSCREW, 3/8-16 UNC-2A X 2.5
18	30601199	PLUG, SAE #10
19	85594403	MANIFOLD GASKET
20	72212162	HYDRAULIC PRESSURE GAGE, 700 BAR
21	70750076	PRESSURE SWITCH ASSEMBLY - INCLUDES ALL WIRING
94	30162144	ELBOW, 90°, SAE 4 MALE - SAE 4 FEMALE
95	30791244	EXTENDER, SAE 4

NOTES: _____

SECTION V

MAINTENANCE (continued)

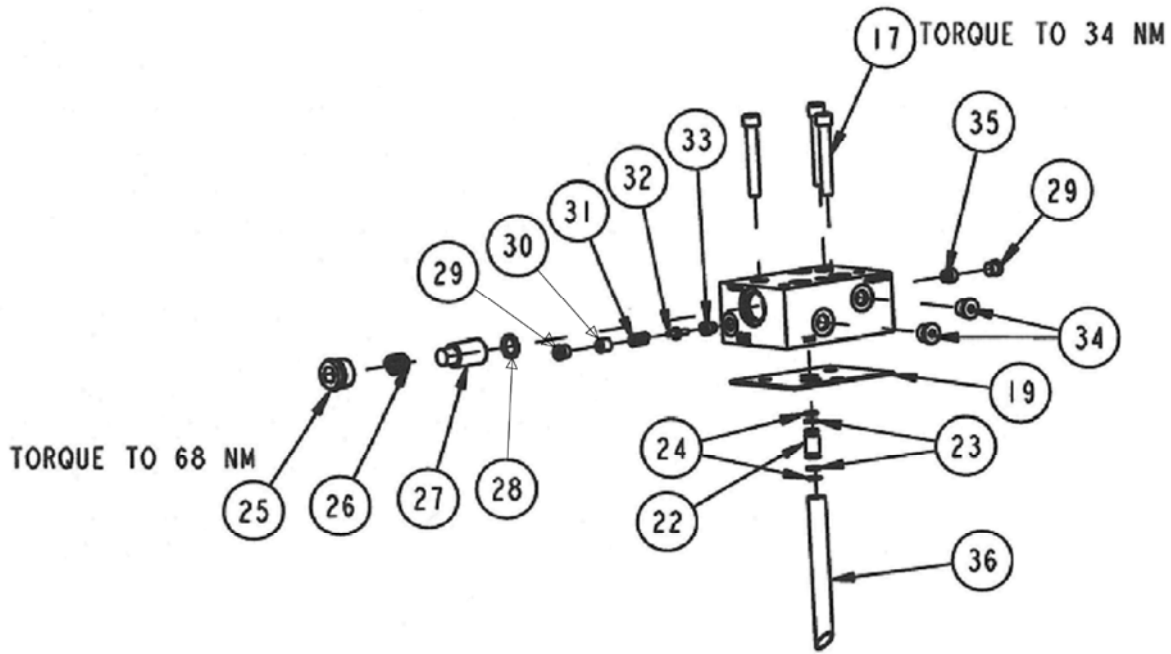

ITEM NO.	PART NO.	DESCRIPTION
22	85534275	TRANSFER TUBE
23	39054010	BACK-UP RING
24	39002009	O-RING
25	30601112	PLUG, SAE #12
26	23313007	SPRING
27	31091005	FILTER, FULL FLOW BRONZE
28	60551200	KIT, SEAL, FILTER, MANIFOLD, PUMP, 3/4HP
29	30601144	PLUG, SAE #4
30	21440025	SCREW, OVER PRESSURE RELIEF ADJUSTMENT
31	23355003	SPRING
32	85534273	NEEDLE, OVER PRESSURE RELIEF
33	85534272	SEAT, OVER PRESSURE RELIEF
34	30601166	PLUG, SAE #6
35	70343792	CHECK VALVE CARTRIDGE
36	85534286	OIL RETURN TUBE

NOTES: _____

SECTION V

MAINTENANCE (continued)

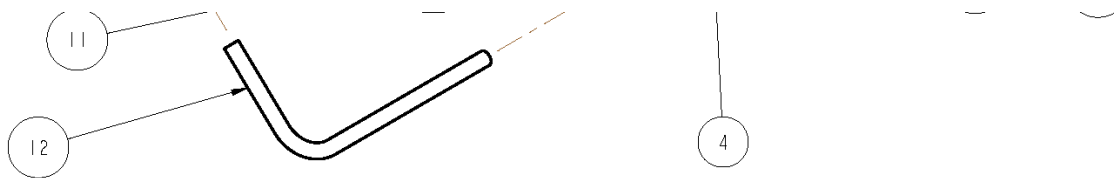

MPLV552100	REV A
------------	-------

SECTION V

MAINTENANCE (continued)
RETURN LINE FILTER ASSEMBLY DETAIL

ITEM NO.	PART NO.	DESCRIPTION
1	21410007	SOCKET HEAD CAPSCREW, 3/8-16 UNC-2A X 3.25 (0 valve)
	21410018	SOCKET HEAD CAPSCREW, 3/8-16 UNC-2A X 6 (1 valve)
	21410042	SOCKET HEAD CAPSCREW, 3/8-16 UNC-2A X 9 (2 valve)
	21410043	SOCKET HEAD CAPSCREW, 3/8-16 UNC-2A X 12 (3 valve)
	21410078	SOCKET HEAD CAPSCREW, 3/8-16 UNC-2A X 15 (4 valve)
2	21410063	SOCKET HEAD CAPSCREW, 1/4-20 UNC-2A X .50
3	21430009	WASHER
4	30000166	CONNECTOR, 3/8 FLRL TB – SAE 6
5	30160166	ELBOW, 90, 3/8 FLRL TB – SAE 6
6	30161166	ELBOW, UNION, 90, SAE 6
7	30601144	PLUG, SAE 4
8	30801246	EXPANDER, MALE SAE 4 – FEM SAE 6
9	30803246	ADAPTER, MALE 1/4 NPT – FEM SAE 6
10	31050015	FILTER HEAD
11	31050014	FILTER, 25 MICRON
12	35000306	HYDRAULIC TUBING, 3/8
13	39000061	O-RING
14	72002110	FILTER GAUGE
15	85592000	FILTER HEAD MOUNT
16	85592001	RETURN FILTER BLOCK

NOTES: _____

SECTION V

MAINTENANCE (continued)
RESERVOIR FILLER CAP/BREATHER ASSEMBLY DETAIL

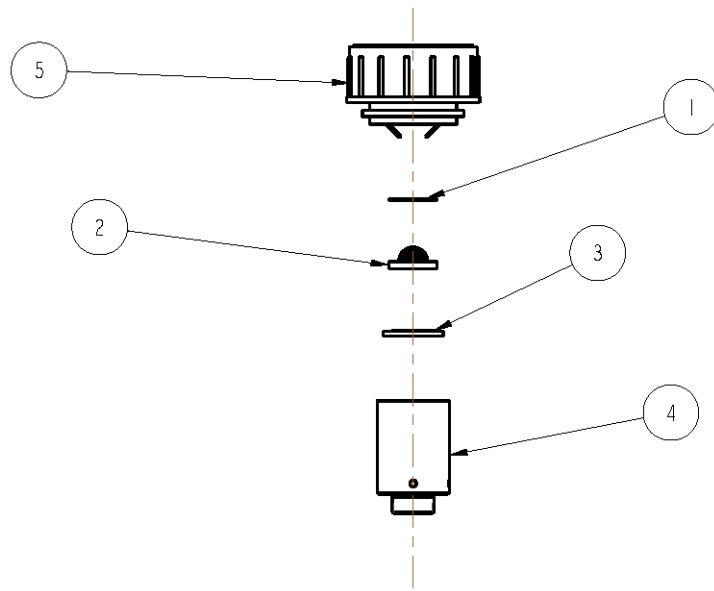

MPLV552101	REV A
------------	-------

ITEM NO.	PART NO.	DESCRIPTION
1	23050028	RETAINING RING
2	31050017	STRAINER, 24 MESH
3	39055012	BONDED SEAL
4	85592002	RESERVOIR BODY
5	85592003	RESERVOIR CAP

NOTES: _____

SECTION V

MAINTENANCE (continued)
VALVE STACK BLOCK ASSEMBLY DETAIL

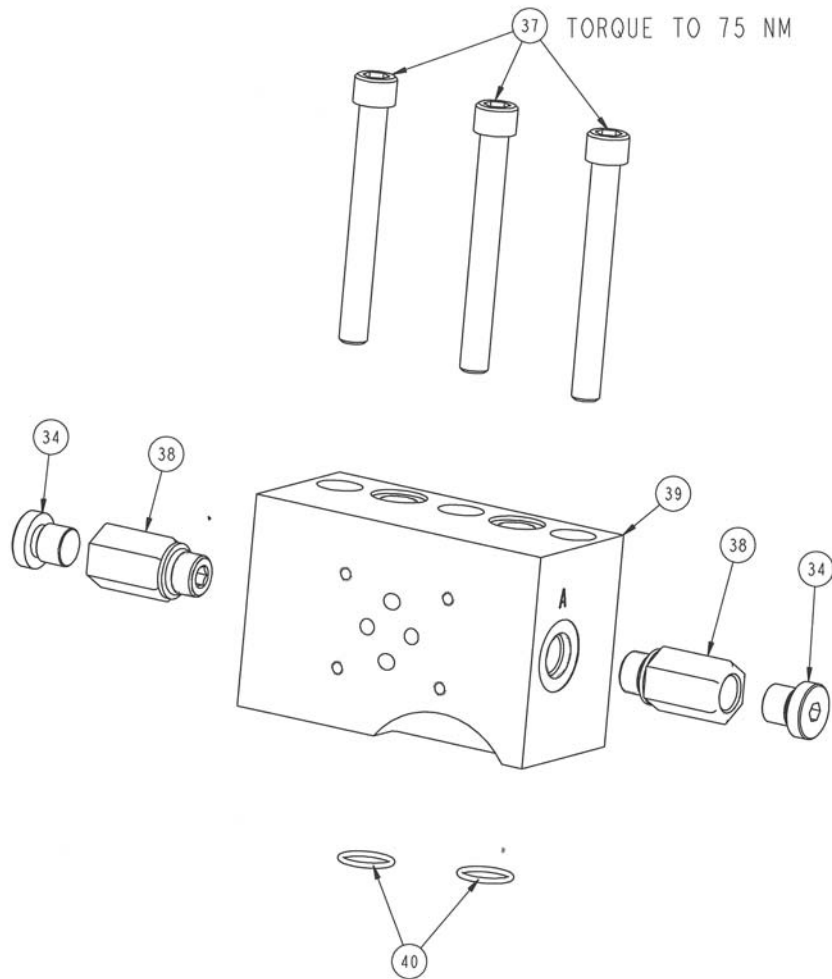

ITEM NO.	PART NO.	DESCRIPTION
34	43068006	PLUG, G 1/4
37	21410007	SOCKET HEAD CAPSCREW, 3/8-16 UNC-2A X 3.25 (1 valve)
	21410018	SOCKET HEAD CAPSCREW, 3/8-16 UNC-2A X 6 (2 valve)
	21410042	SOCKET HEAD CAPSCREW, 3/8-16 UNC-2A X 9.31 (3 valve)
	21410043	SOCKET HEAD CAPSCREW, 3/8-16 UNC-2A X 12.19 (4 valve)
38	47004170	FILTER, G 1/4 INLINE
39	83107804	STACK BLOCK
40	39000061	O-RING

NOTES: _____

SECTION V

MAINTENANCE (continued)
2/3 MANUAL VALVE ASSEMBLY DETAIL

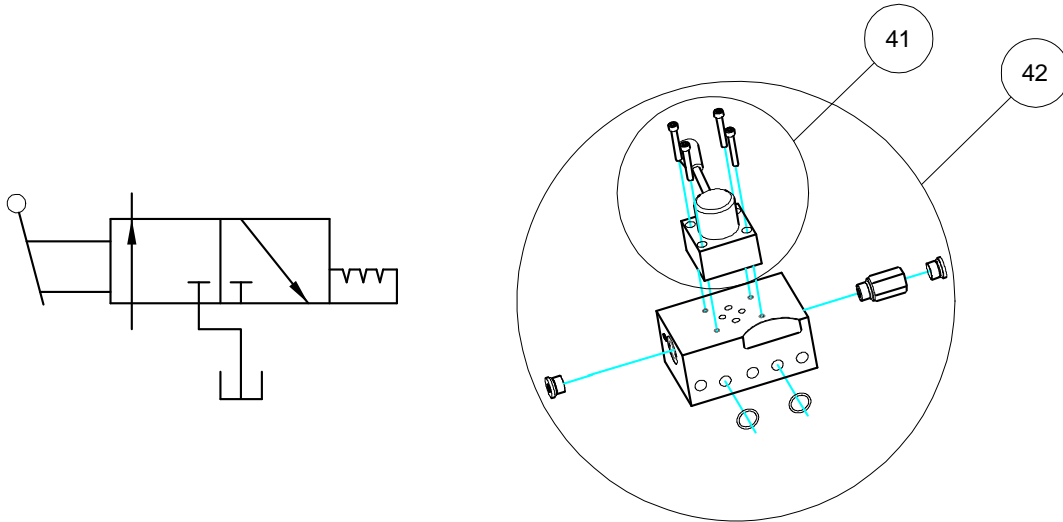

ITEM NO.	PART NO.	DESCRIPTION
41	71142202	VALVE, 2/3 MANUAL
42	94559206	KIT, VALVE, 2/3 MANUAL
92	70342500	P-CHECK SUB-PLATE - MULTIPLE VALVE PUMPS - NOT SHOWN*
		*NOTE: USE SCREWS #93
93	21410012	SCREW, #10-24 X 3.5

NOTES: _____

SECTION V

MAINTENANCE (continued)
3/4 CLOSED CENTER MANUAL VALVE ASSEMBLY DETAIL

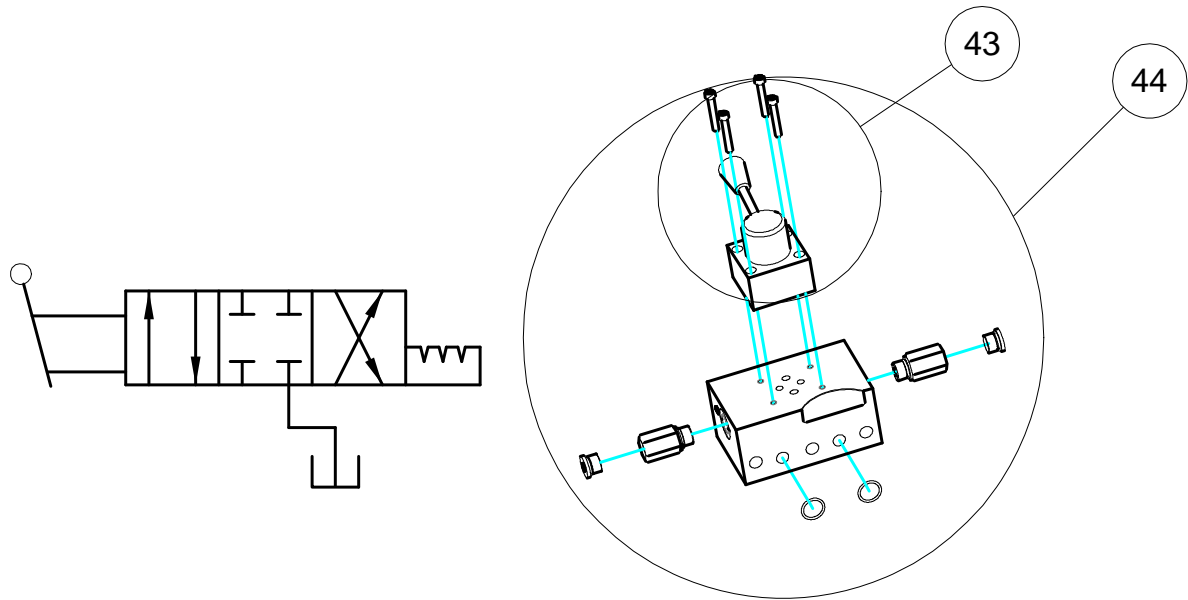

ITEM NO.	PART NO.	DESCRIPTION
43	71147200	VALVE, 3/4, MANUAL, CLOSED CENTER
44	94559208	KIT, VALVE, 3/4, MANUAL, CLOSED CENTER
92	70342500	P-CHECK SUB-PLATE - MULTIPLE VALVE PUMPS - NOT SHOWN*
		*NOTE: USE SCREWS #93
93	21410012	SCREW, #10-24 X 3.5

NOTES: _____

SECTION V

MAINTENANCE (continued)
3/4 P-BLOCKED CENTER MANUAL VALVE ASSEMBLY DETAIL

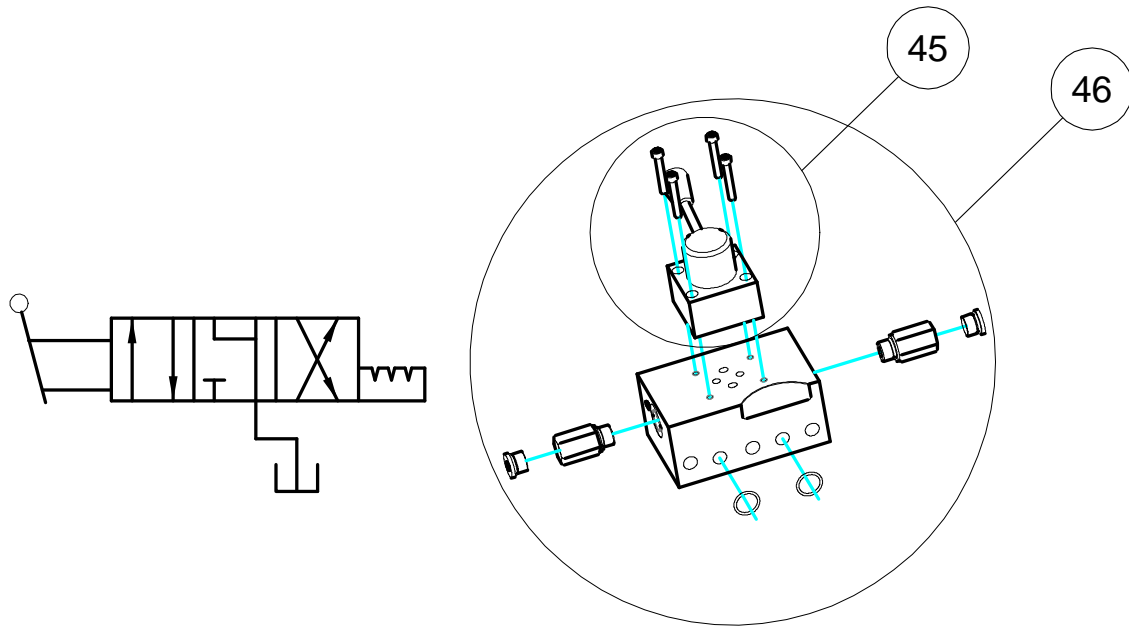

ITEM NO.	PART NO.	DESCRIPTION
45	71147400	VALVE, 3/4, MANUAL, P-BLOCKED CENTER
46	94559209	KIT, VALVE, 3/4, MANUAL, P-BLOCKED
92	70342500	P-CHECK SUB-PLATE - MULTIPLE VALVE PUMPS - NOT SHOWN*
		*NOTE: USE SCREWS #93
93	21410012	SCREW, #10-24 X 3.5

NOTES: _____

SECTION V

MAINTENANCE (continued)
2/3 NORMALLY CLOSED 24VDC VALVE ASSEMBLY DETAIL

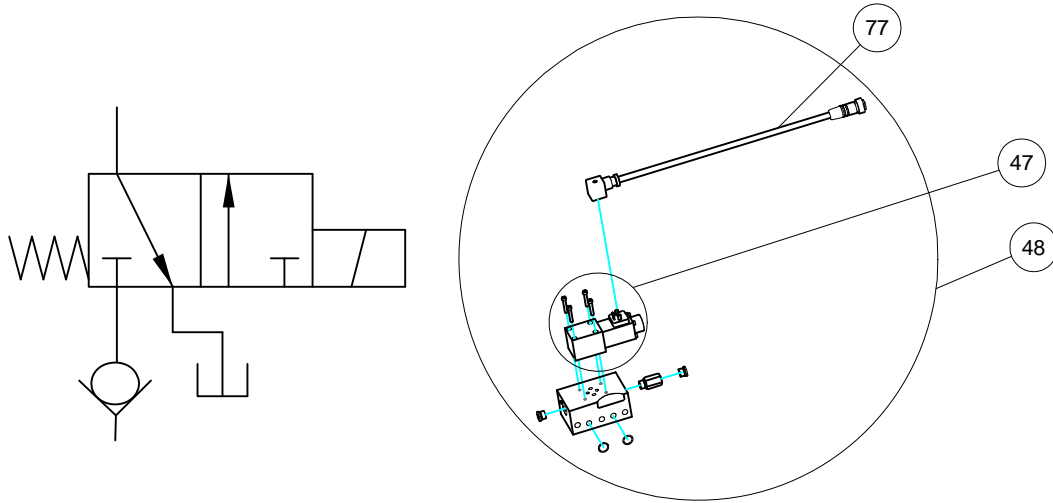

ITEM NO.	PART NO.	DESCRIPTION
47	71115003	VALVE, 2/3, 24VDC, NORMALLY CLOSED
48	94559212	KIT, VALVE, 2/3, 24VDC, NORMALLY CLOSED
77	27721801	VALVE CONTROL CABLE

NOTES: _____

SECTION V

MAINTENANCE (continued)
2/3 NORMALLY OPEN 24VDC VALVE ASSEMBLY DETAIL

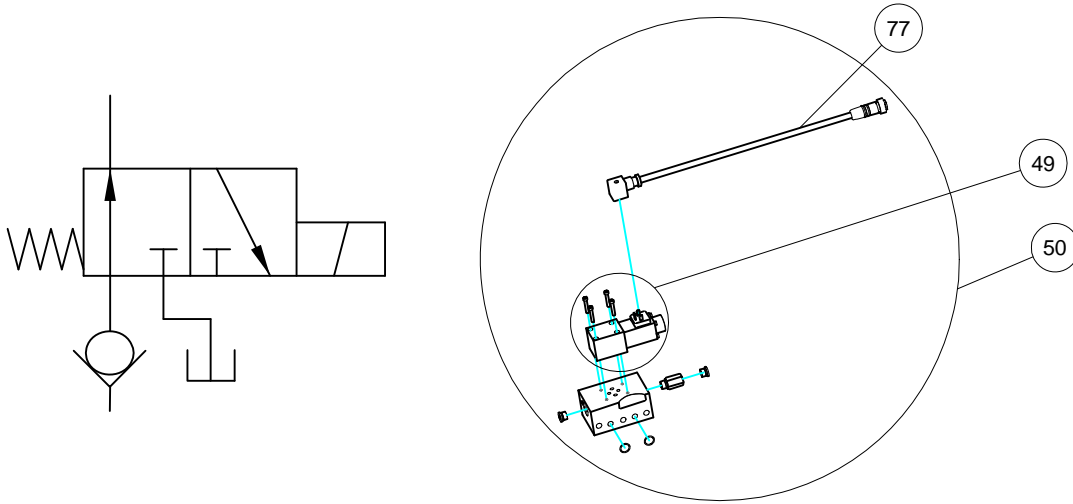

ITEM NO.	PART NO.	DESCRIPTION
49	71112254	VALVE, 2/3, 24VDC, NORMALLY OPEN
50	94559207	KIT, VALVE, 2/3, 24VDC, NORMALLY OPEN
77	27721801	VALVE CONTROL CABLE

NOTES: _____

SECTION V

MAINTENANCE (continued)
3/4 CLOSED CENTER 24VDC VALVE ASSEMBLY DETAIL

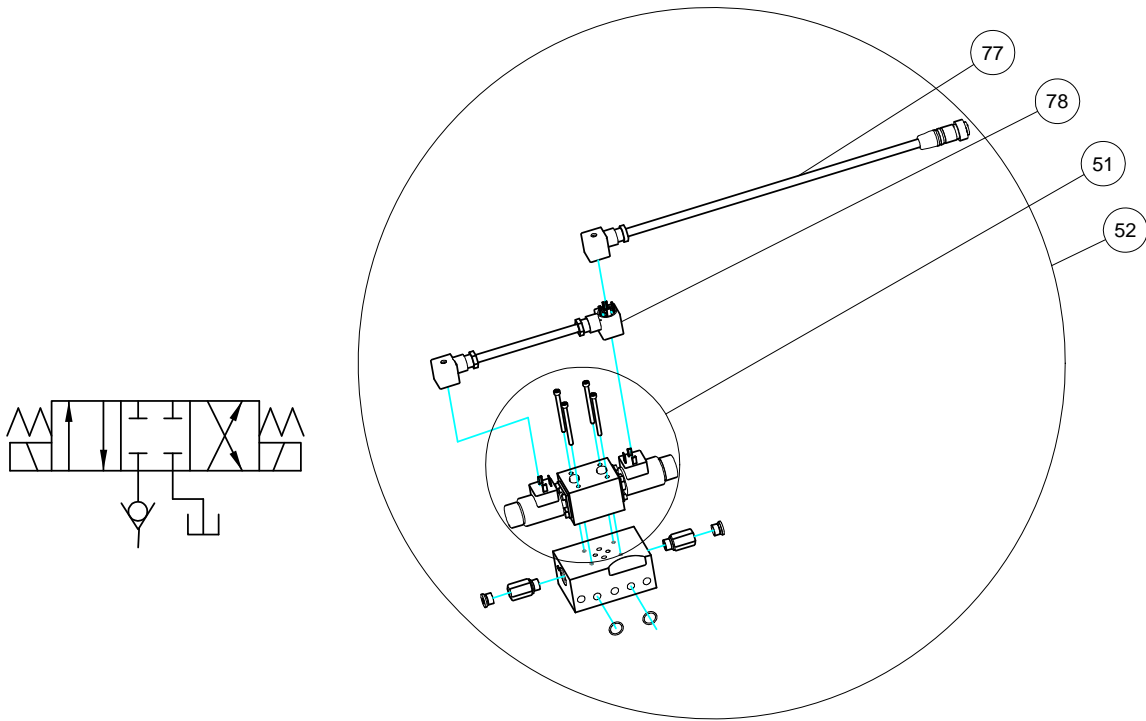

ITEM NO.	PART NO.	DESCRIPTION
51	71123521	VALVE, 3/4, 24VDC, CLOSED CENTER
52	94559210	KIT, VALVE, 3/4, 24VDC, CLOSED CENTER
77	27721801	VALVE CONTROL CABLE
78	85534234	DOUBLE SOLENOID CABLE

NOTES: _____

SECTION V

MAINTENANCE (continued)
3/4 P-BLOCKED CENTER 24VDC VALVE ASSEMBLY DETAIL

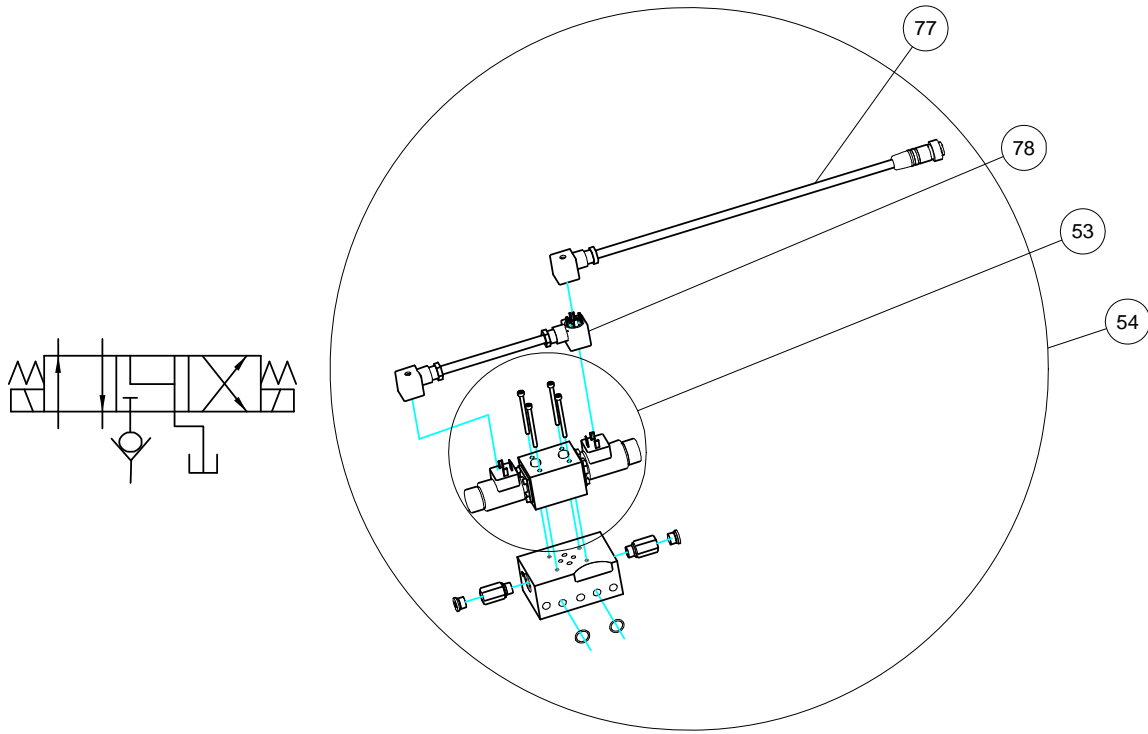

ITEM NO.	PART NO.	DESCRIPTION
53	71123540	VALVE, 3/4, 24VDC, P-BLOCKED CENTER
54	94559211	KIT, VALVE, 3/4, 24VDC, P-BLOCKED CENTER
77	27721801	VALVE CONTROL CABLE
78	85534234	DOUBLE SOLENOID CABLE

NOTES: _____

SECTION V

MAINTENANCE (continued)

3 POSITION MAINTAINED/MOMENTARY PENDANT ASSEMBLY DETAIL

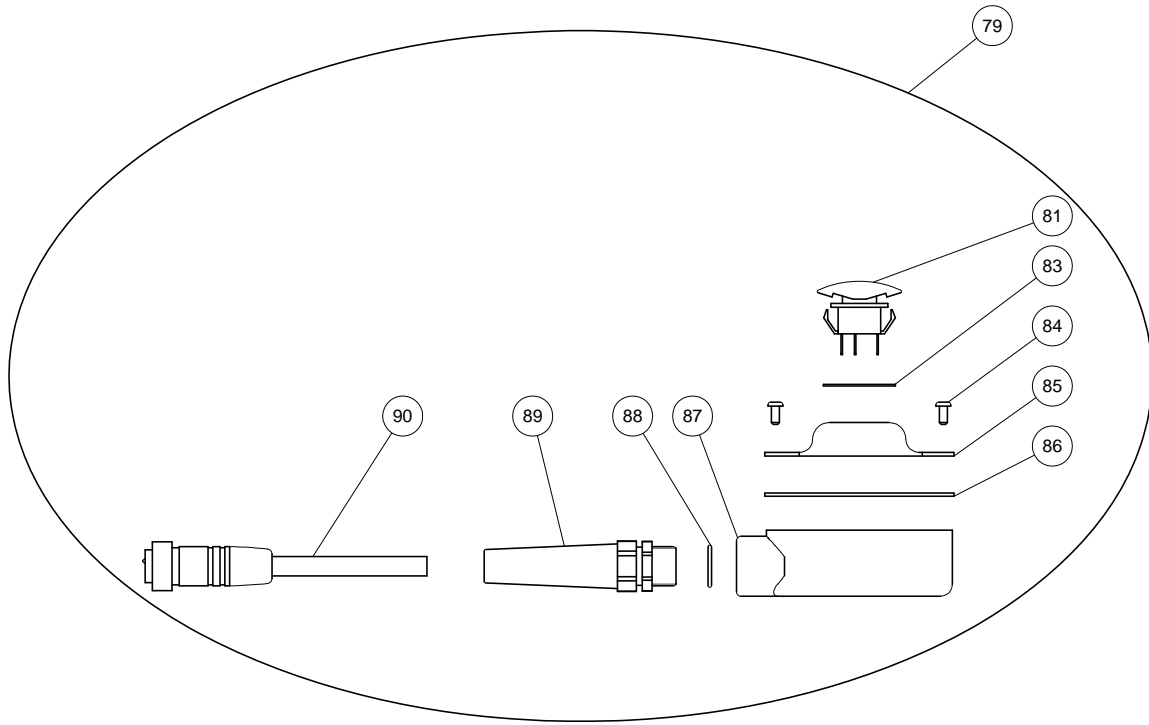

ITEM NO.	PART NO.	DESCRIPTION
79	70740776	PENDANT ASSEMBLY, 3 POSITION MAINTAINED SWITCH, 6FT
	70740778	PENDANT ASSEMBLY, 3 POSITION MOMENTARY SWITCH, 6FT
	70740782	PENDANT ASSEMBLY, 3 POSITION MAINTAINED SWITCH, 6M
	70740784	PENDANT ASSEMBLY, 3 POSITION MOMENTARY SWITCH, 6M
81	29123101	3 POSITION MAINTAINED CONTACT SWITCH
	29124101	3 POSITION MOMENTARY/OFF/ON CONTACT SWITCH
83	39050027	SWITCH GASKET
84	21410008	SCREW, #8-32 X .5
85	25631003	COVER PLATE
86	39050025	COVER PLATE GASKET
87	25231100	PENDANT BOX
88	39050026	STRAIN RELIEF SEAL
89	28512401	STRAIN RELIEF
90	27511640	PENDANT CABLE, 6 FT
	27511643	PENDANT CABLE, 6M

NOTES: _____

SECTION V

MAINTENANCE (continued)

2 POSITION MAINTAINED/MOMENTARY PENDANT ASSEMBLY DETAIL

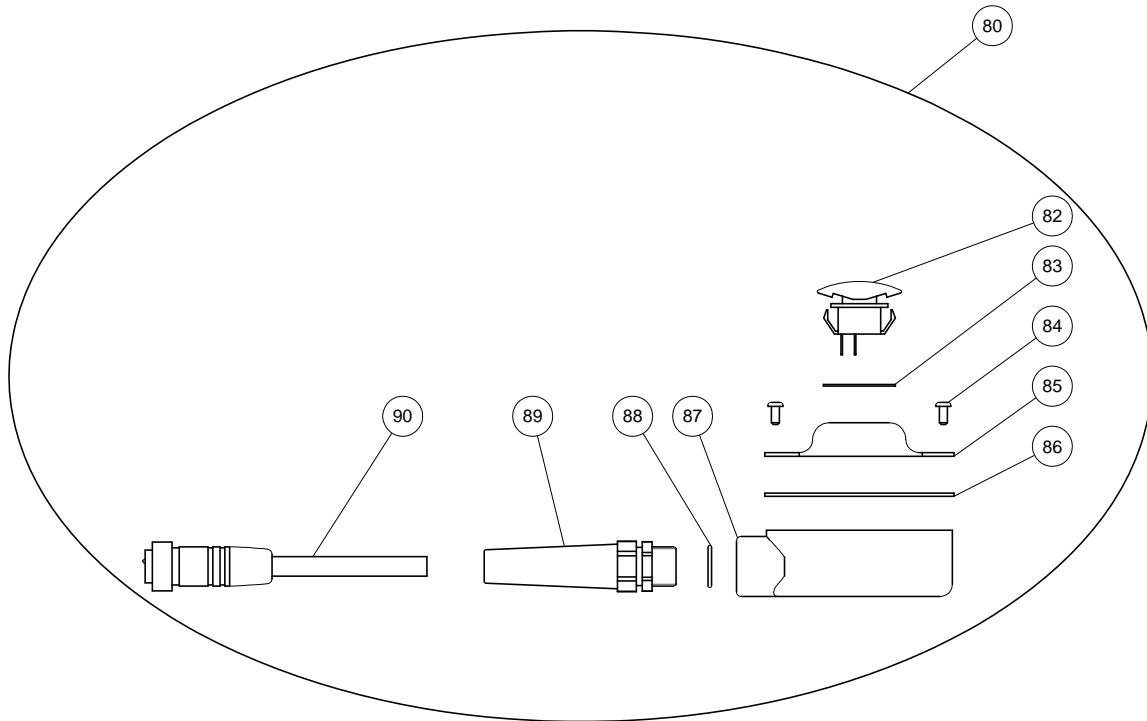

ITEM NO.	PART NO.	DESCRIPTION
80	70740777	PENDANT ASSEMBLY, 2 POSITION MAINTAINED, N/O VLV, 6FT
	70740779	PENDANT ASSEMBLY, 2 POSITION MOMENTARY, S/A, PD, 6FT
	70740780	PENDANT ASSEMBLY, 2 POSITION MOMENTARY, N/C VLV, 6FT
	70740783	PENDANT ASSEMBLY, 2 POSITION MAINTAINED, N/O VLV, 6M
	70740785	PENDANT ASSEMBLY, 2 POSITION MOMENTARY, S/A, PD, 6M
	70740786	PENDANT ASSEMBLY, 2 POSITION MOMENTARY, N/C VLV, 6M
82	29121101	2 POSITION MAINTAINED CONTACT SWITCH
	29122101	2 POSITION MOMENTARY CONTACT SWITCH
83	39050027	SWITCH GASKET
84	21410008	SCREW, #8-32 X .5
85	25631003	COVER PLATE
86	39050025	COVER PLATE GASKET
87	25231100	PENDANT BOX
88	39050026	STRAIN RELIEF SEAL
89	28512401	STRAIN RELIEF
90	27511640	PENDANT CABLE, 6FT
	27511643	PENDANT CABLE, 6M

SECTION V

MAINTENANCE (continued)
MACHINE TO PUMP CONTROL CABLE ASSEMBLY DETAIL

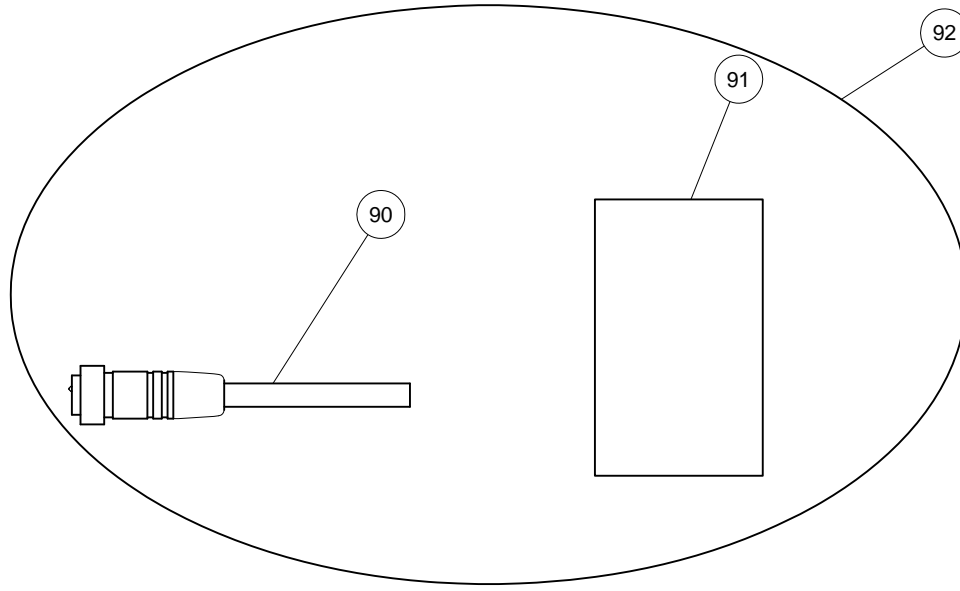

ITEM NO.	PART NO.	DESCRIPTION
90	27511643	PENDANT CABLE, 6M
91	IS7074	INSTRUCTION SHEET, (See SECTION IX for wiring)
92	95534228	KIT, MACHINE CONTROLLER INTERFACE

NOTES: _____

SECTION V

MAINTENANCE (continued)
ELECTICAL CONTROL BOX ASSEMBLY DETAIL

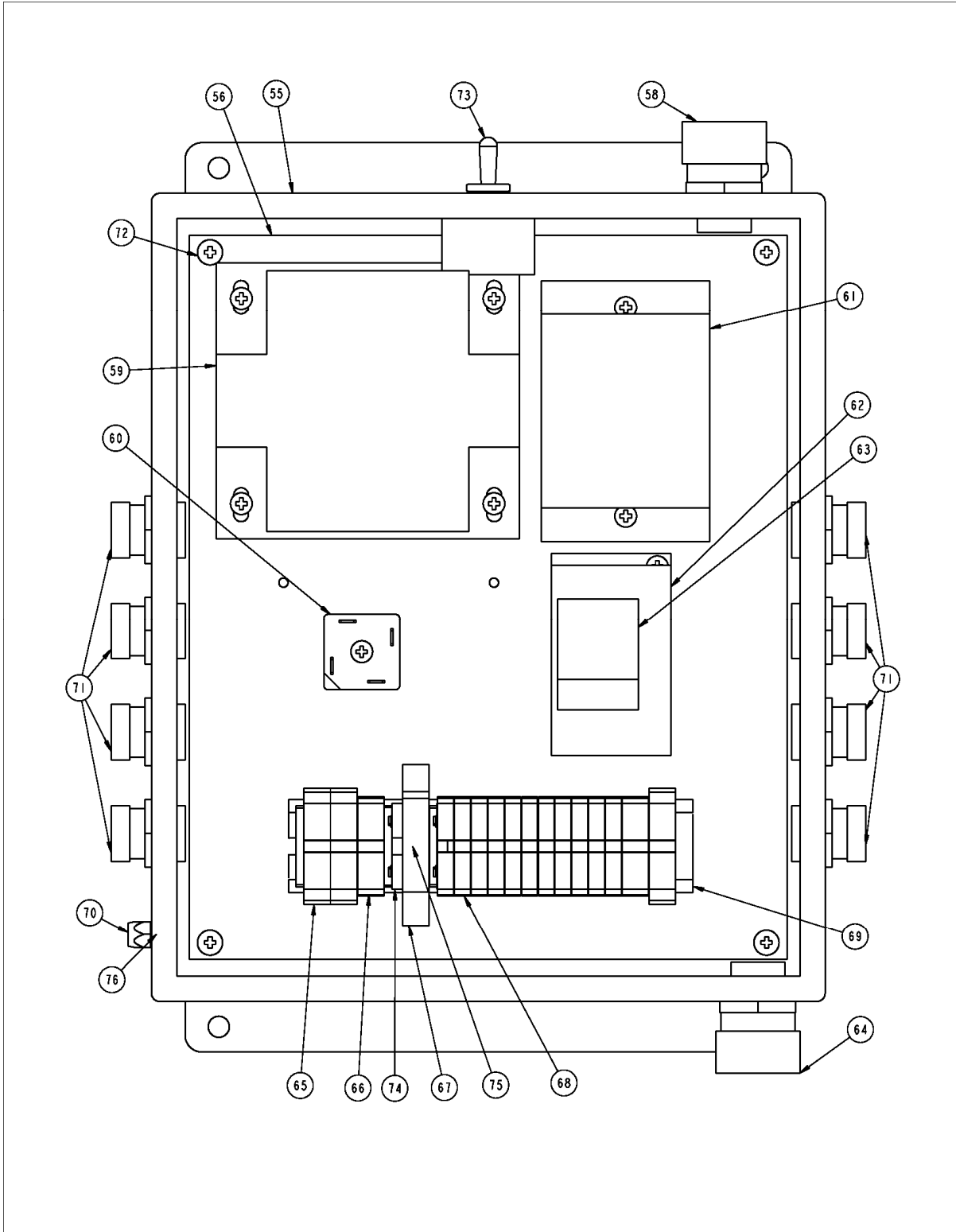

SECTION V

MAINTENANCE (continued)

ITEM NO.	PART NO.	DESCRIPTION
55	85534283	ELECTRICAL BOX, PREPUNCHED HOLES (0 valve)
	85534284	ELECTRICAL BOX, PREPUNCHED HOLES (2 valve)
	85534285	ELECTRICAL BOX, PREPUNCHED HOLES (4 valve)
56	85534290	BACK PLATE, PRE-DRILLED
58	28612600	STRAIN RELIEF – 230/380/440VAC
59	84559200	TRANSFORMER
60	85534287	RECTIFIER
61	85534281	CONTACTOR
62	28731130	OVERLOAD FRAME - REQUIRES OVERLOAD PACK
63	28731132	OVERLOAD PACK – 230/380VAC
	28731148	OVERLOAD PACK - 440VAC
64	28612600	STRAIN RELIEF
65	28731123	TERMINAL BLOCK, GROUND
66	28731126	TERMINAL BLOCK, 4 WIRE
67	28731122	TERMINAL BLOCK, FUSE
68	28731124	TERMINAL BLOCK, 2 WIRE
69	85534288	MOUNTING RAIL
70	27622200	INTERLOCK CONNECTOR
71	27611640	VALVE/PENDANT CONNECTOR
72	21411025	SELF TAPPING SCREW, #8-32 X .5
73	28731137	POWER SWITCH
74	28731146	TERMINAL BLOCK END PLATE
75	29300001	FUSE, 5A
76	27622201	INTERLOCK CONNECTOR NUT

NOTES: _____

SECTION V

MAINTENANCE (continued)

C. Wiring Diagram

D. 220VAC Pump Equipped with 24VDC Valve(s)

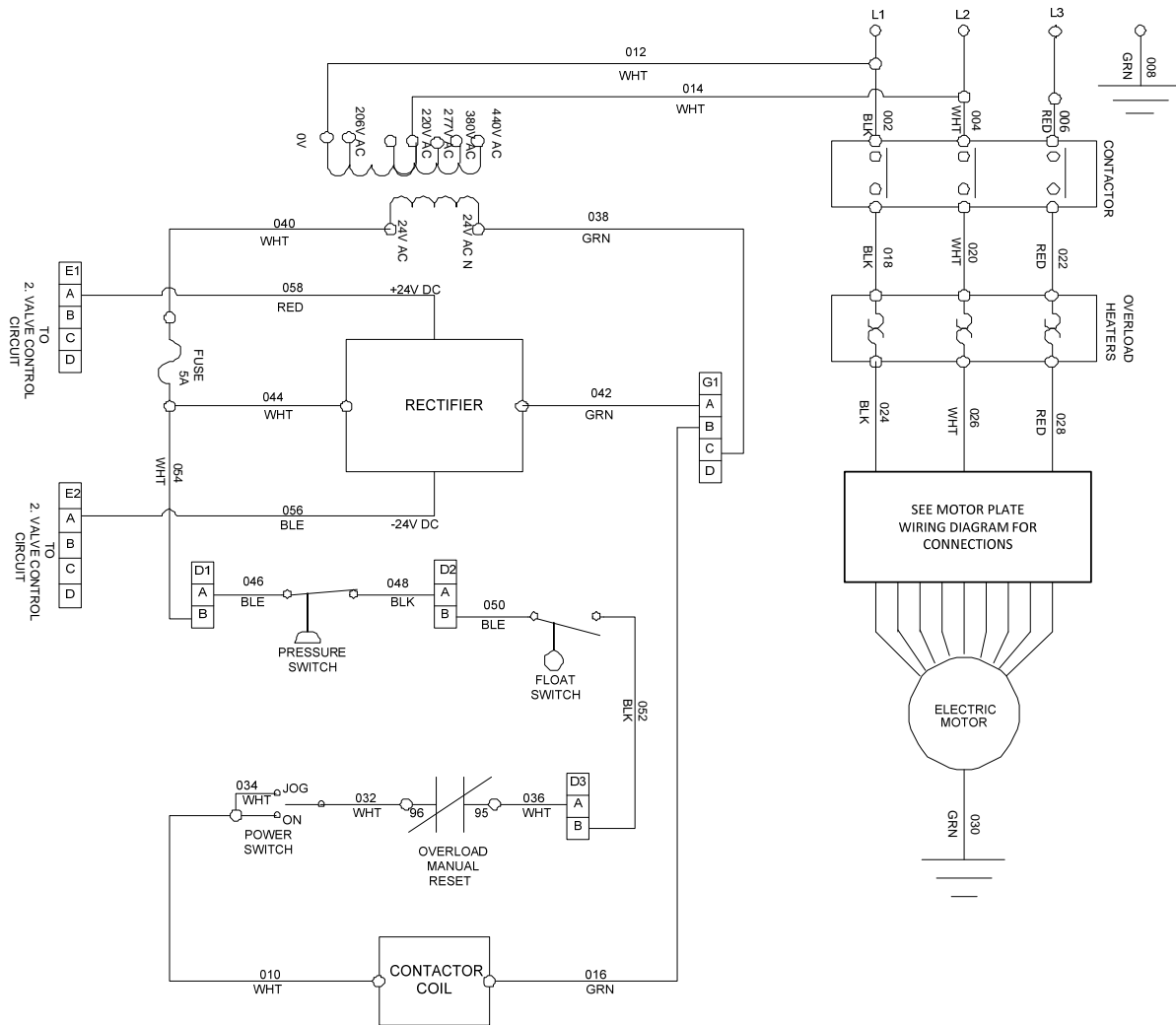

- | | | |
|--------------|------------|------------|
| Pump Models: | 45-5924-33 | 45-5924-07 |
| | 45-5924-36 | 45-5924-16 |
| | 45-5924-37 | 45-5924-20 |
| | 45-5924-38 | 45-5924-26 |
| | 45-5924-03 | 45-5924-09 |
| | 45-5924-14 | 45-5924-18 |
| | 45-5924-22 | 45-5924-28 |
| | 45-5924-24 | 45-5924-30 |

SECTION V

MAINTENANCE (continued)

C. Wiring Diagram

E. 380VAC Pump Equipped with 0 or Manual Valve(s)

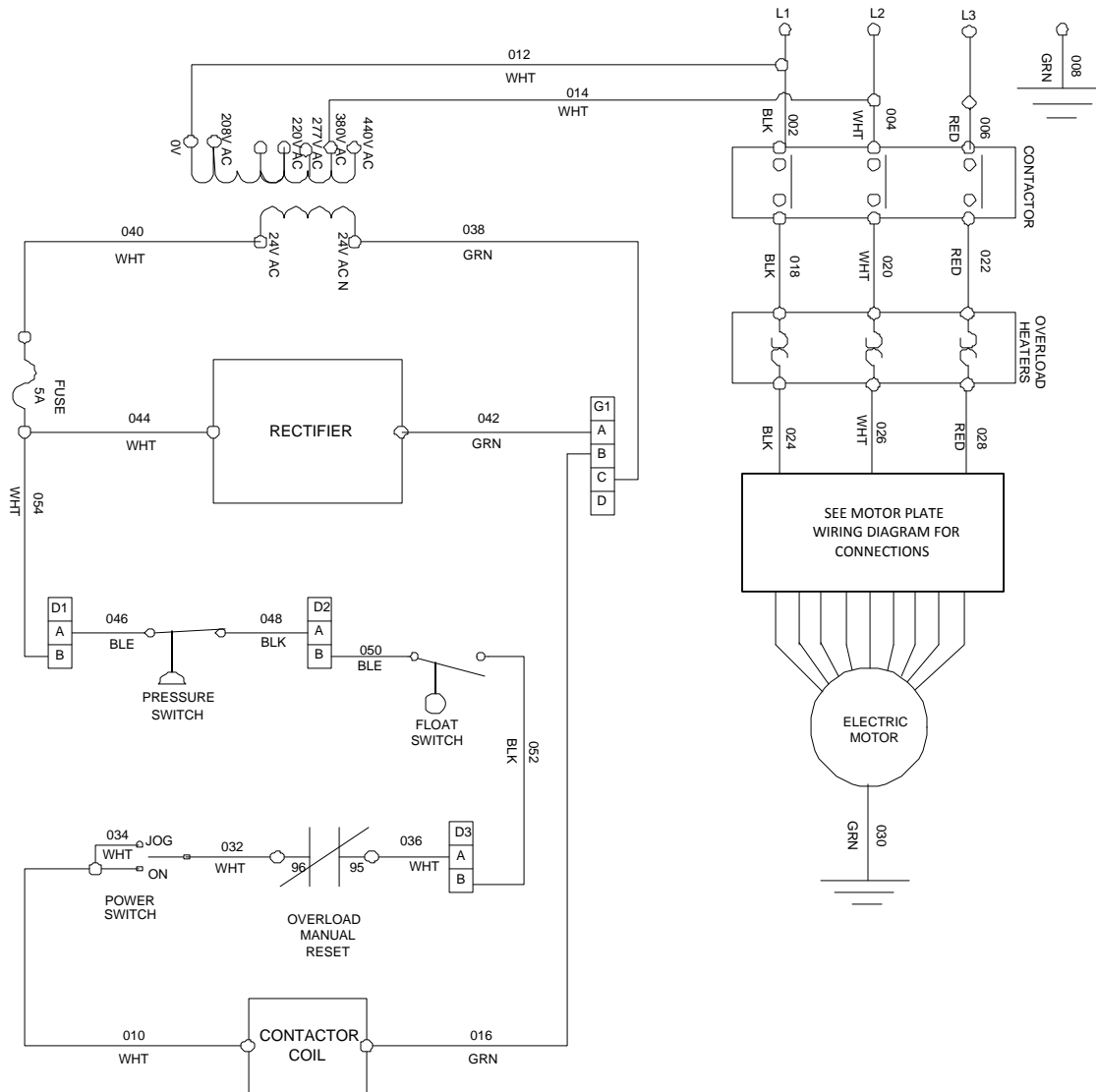

Pump Models:	45-5927-32	45-5927-46
	45-5927-47	45-5927-01
	45-5927-05	45-5927-17
	45-5927-48	45-5927-23
	45-5927-11	45-5927-29
	45-5927-49	45-5927-45

SECTION V

MAINTENANCE (continued)

C. Wiring Diagram

F. 380VAC Pump Equipped with 24VDC Valve(s)

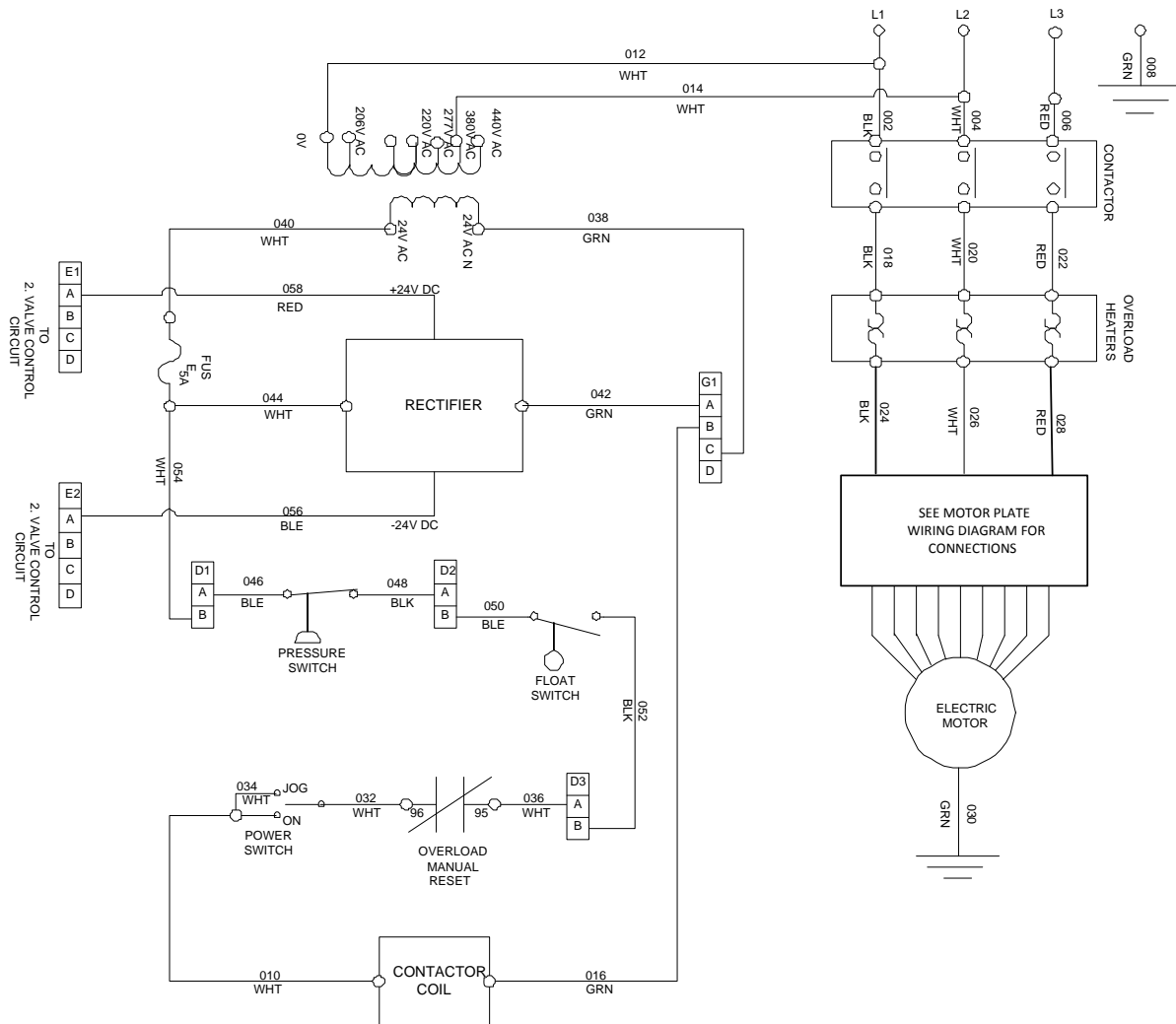

- | | | |
|--------------|------------|------------|
| Pump Models: | 45-5927-33 | 45-5927-07 |
| | 45-5927-36 | 45-5927-16 |
| | 45-5927-37 | 45-5927-20 |
| | 45-5927-38 | 45-5927-26 |
| | 45-5927-03 | 45-5927-09 |
| | 45-5927-14 | 45-5927-18 |
| | 45-5927-22 | 45-5927-28 |
| | 45-5927-24 | 45-5927-30 |

SECTION V

MAINTENANCE (continued)

C. Wiring Diagram

G. 440VAC Pump Equipped with 0 or Manual Valve(s)

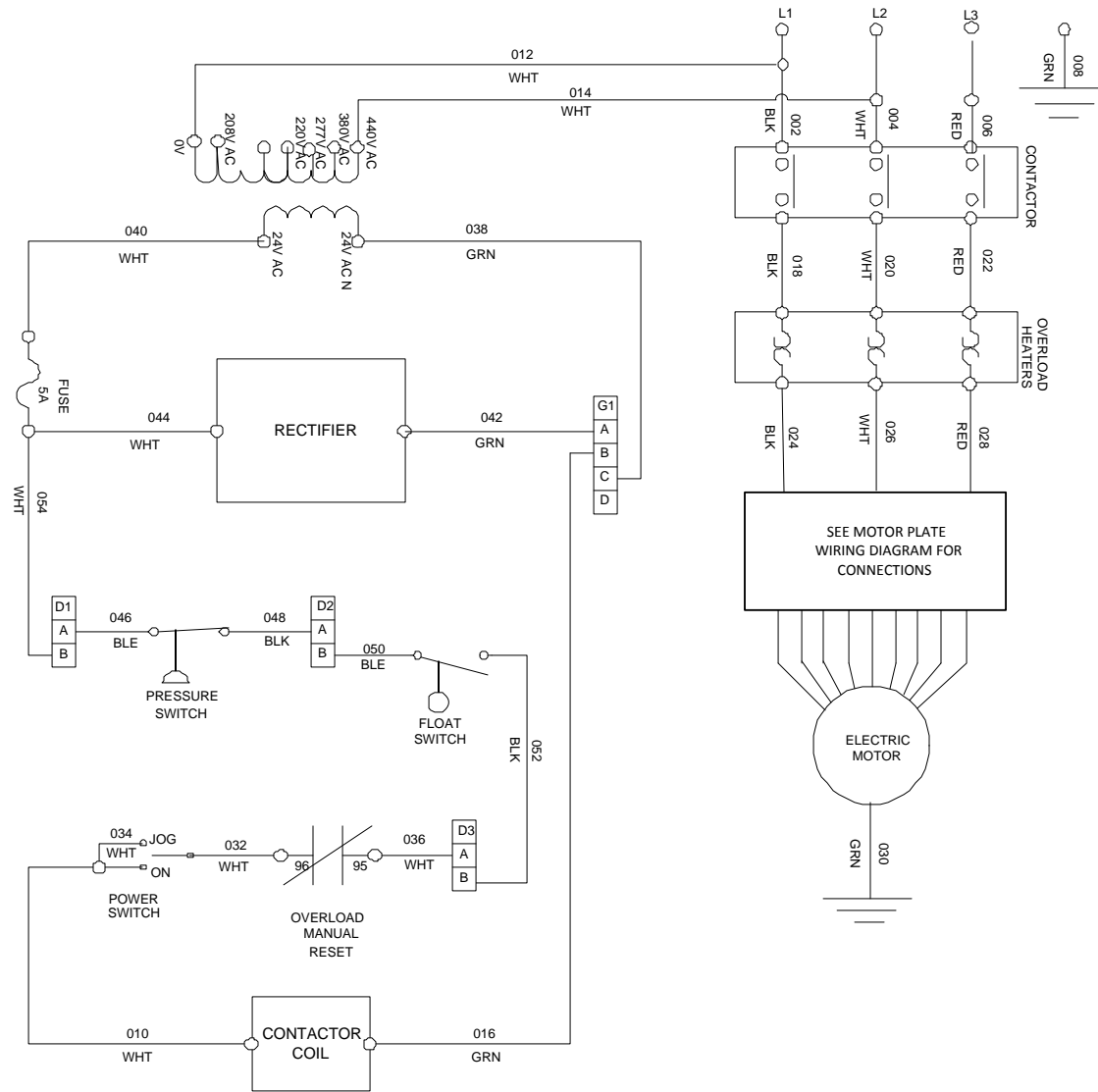

- | | | |
|---------------------|------------|------------|
| Pump Models: | 45-5929-32 | 45-5929-45 |
| | 45-5929-01 | 45-5929-46 |
| | 45-5929-48 | 45-5929-47 |
| | 45-5929-11 | 45-5929-05 |
| | 45-5929-49 | 45-5929-17 |
| | 45-5929-04 | 45-5929-23 |
| | 45-5929-29 | |

SECTION V

MAINTENANCE (continued)

C. Wiring Diagram

H. 440VAC Pump Equipped with 24VDC Valve(s)

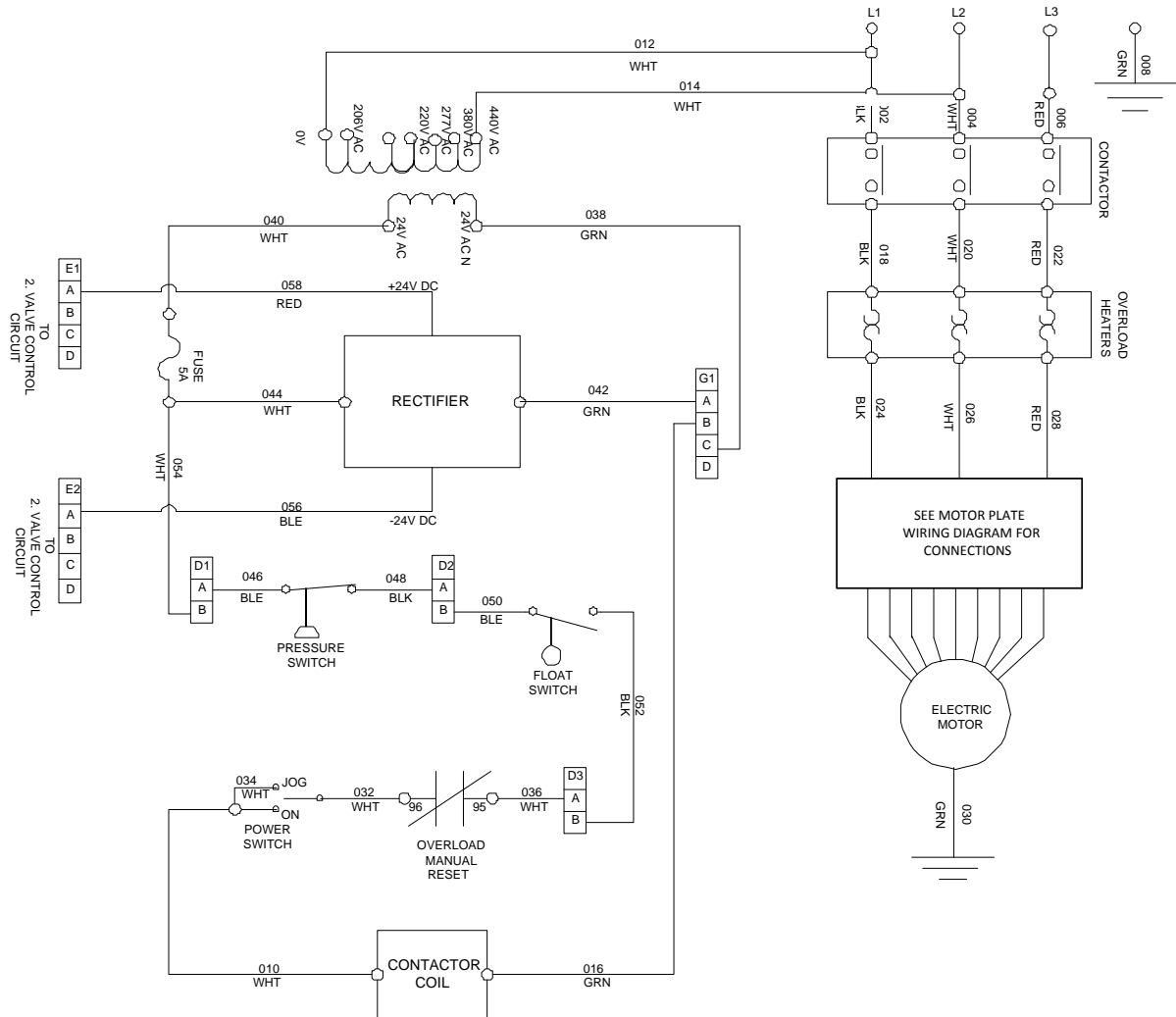

- | | | |
|--------------|------------|------------|
| Pump Models: | 45-5929-33 | 45-5929-07 |
| | 45-5929-36 | 45-5929-16 |
| | 45-5929-37 | 45-5929-20 |
| | 45-5929-38 | 45-5929-26 |
| | 45-5929-03 | 45-5929-09 |
| | 45-5929-14 | 45-5929-18 |
| | 45-5929-22 | 45-5929-28 |
| | 45-5929-24 | 45-5929-30 |

SECTION V

MAINTENANCE (continued)

C. Wiring Diagram

1. Valve Control Circuit

A. 2 Valve Control Circuit

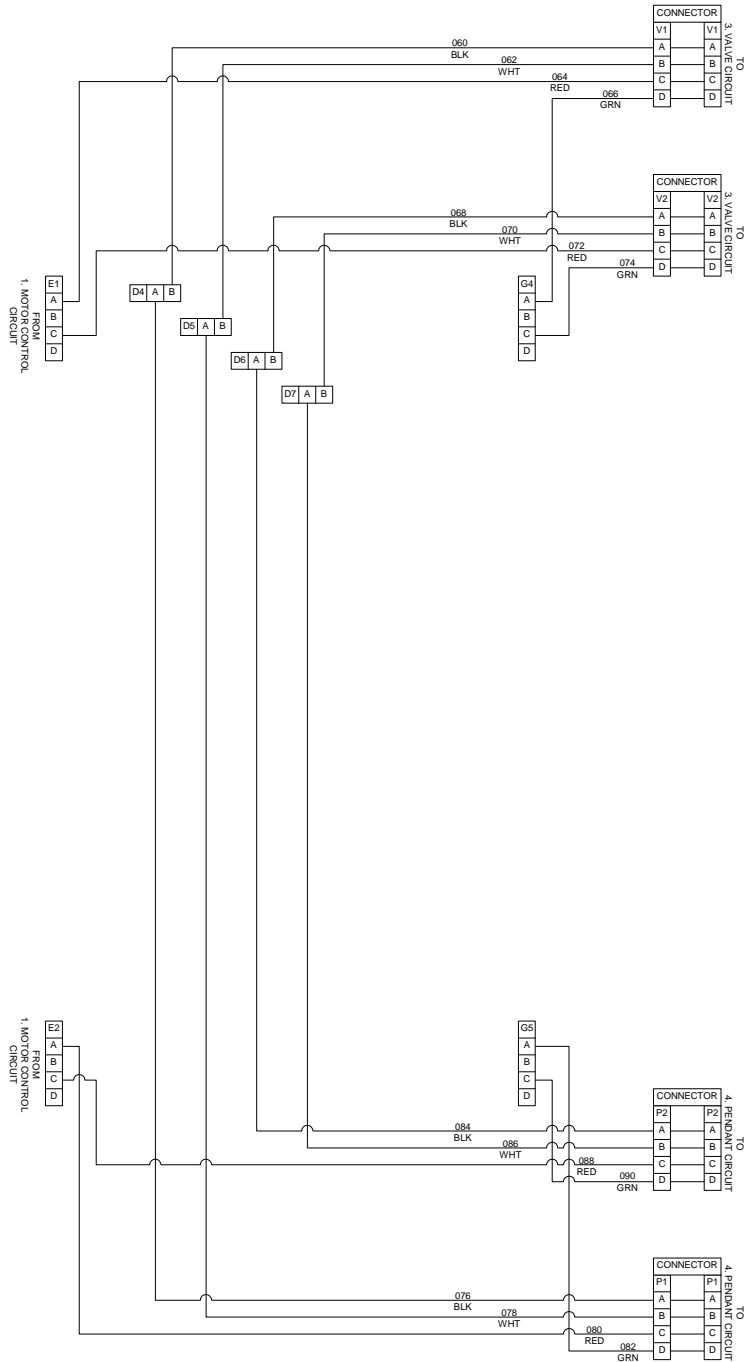

- Pump Models:
- 45-5924-35
 - 45-5924-33
 - 45-5924-36
 - 45-5924-03
 - 45-5924-14
 - 45-5924-07
 - 45-5924-16
 - 45-5924-09
 - 45-5924-18
 - 45-5927-35
 - 45-5927-33
 - 45-5927-36
 - 45-5927-03
 - 45-5927-14
 - 45-5927-07
 - 45-5927-16
 - 45-5927-09
 - 45-5927-18
 - 45-5929-35
 - 45-5929-33
 - 45-5929-36
 - 45-5929-03
 - 45-5929-14
 - 45-5929-07
 - 45-5929-16
 - 45-5929-09
 - 45-5929-18

SECTION V

MAINTENANCE (continued)

C. Wiring Diagram

B. 4 Valve Control Circuit

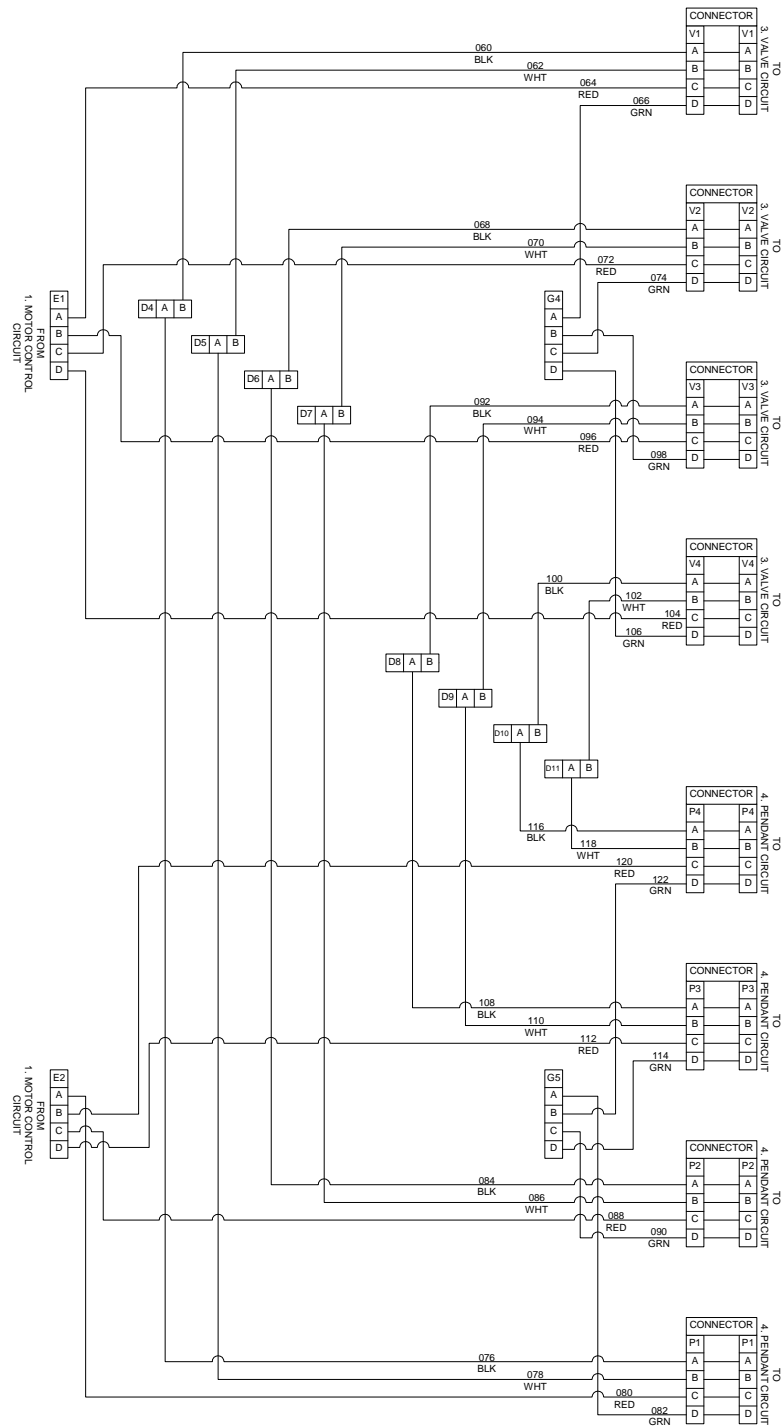

- Pump Models:**
- 45-5924-37
 - 45-5924-38
 - 45-5924-20
 - 45-5924-26
 - 45-5924-22
 - 45-5924-28
 - 45-5924-24
 - 45-5927-30
 - 45-5927-37
 - 45-5927-38
 - 45-5927-20
 - 45-5927-26
 - 45-5927-22
 - 45-5927-28
 - 45-5927-24
 - 45-5927-30
 - 45-5929-37
 - 45-5929-38
 - 45-5929-20
 - 45-5929-26
 - 45-5929-22
 - 45-5929-28
 - 45-5929-24
 - 45-5929-30

SECTION V

MAINTENANCE (continued)

C. Wiring Diagram

2. Valve Circuit

A. 3/4 Valve

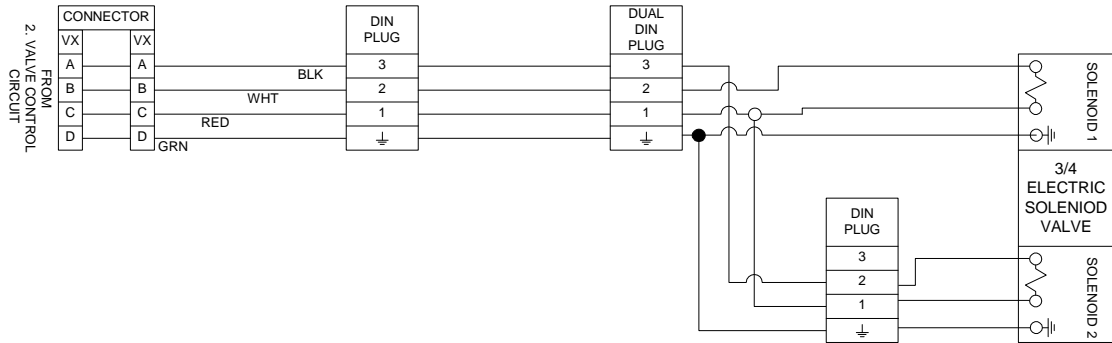

Valve Models: 71-1235-21 71-1235-40

B. 2/3 Valve Circuit

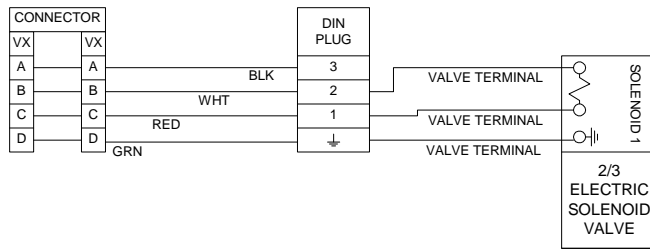

Valve Models: 47-1112-54 47-1115-03

SECTION V

MAINTENANCE (continued)

C. Wiring Diagram

3. Pendant Circuit

A. 3 Position Pendant

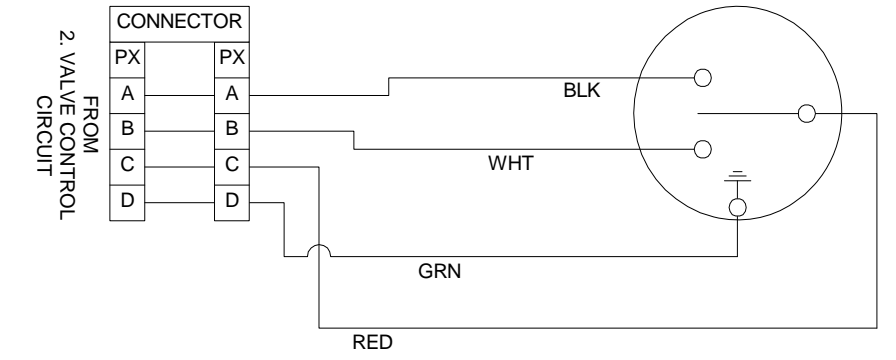

Pendant Models: 70-7407-76 70-7407-78
 70-7407-82 70-7407-84

B. 3 Position Pendant

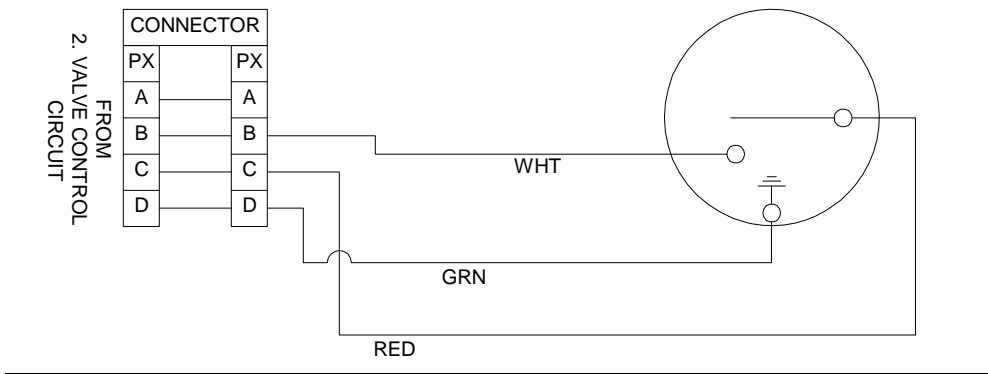

Pendant Models: 70-7407-77 70-7407-79 70-7407-80
 70-7407-83 70-7407-85 70-7407-86

SECTION V

MAINTENANCE (continued)

BASIC 1 HP PUMP SCHEMATIC

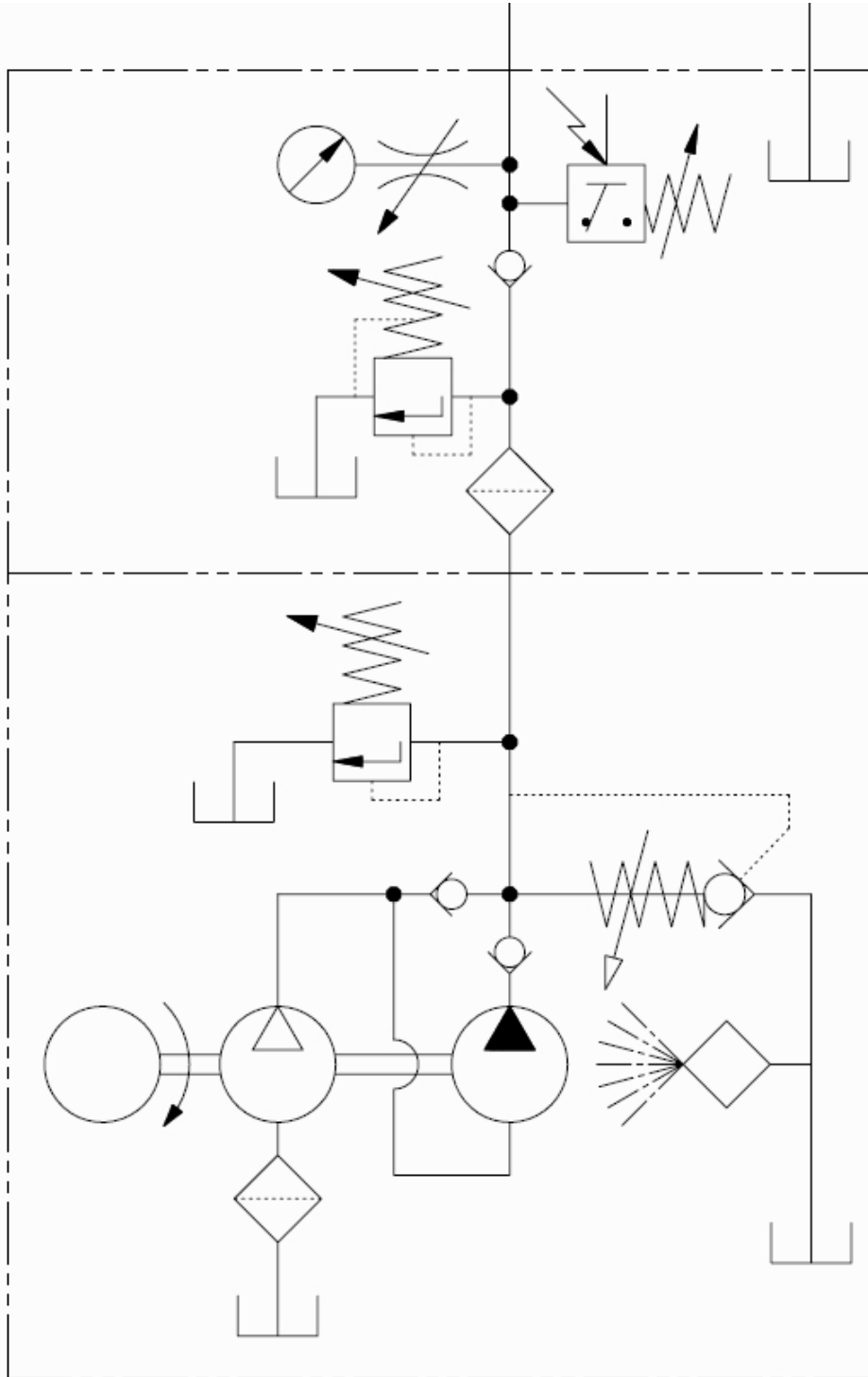

SECTION VI

TROUBLE SHOOTING

Symptom	Cause	Solution
Sporadic Cylinder Operation	<ol style="list-style-type: none"> 1. Air in the hydraulic system. 2. Low oil level in pump. 	<ol style="list-style-type: none"> 1. See Section III C for bleeding procedure. 2. Check oil level.
Motor Will Not Start	<ol style="list-style-type: none"> 1. No electrical power. 2. Manual Overload Tripped. 3. Power cord damaged. 4. Oil level too low. 5. Motor starter capacitor faulty. 6. Loose or faulty wiring. 7. Power switch defective. 8. Oil level switch defective. 	<ol style="list-style-type: none"> 1. Check for tripped circuit breaker and/ or correct rating. 2. Reset switch. (See Section V Pump Assembly Detail B for switch location) 3. Replace power cord. 4. Fill reservoir to 13mm below top plate with correct oil. 5. Check for faulty capacitor. 6. Inspect for loose or faulty wiring. 7. Replace switch. 8. Replace switch assembly.
Noisy Operation	<ol style="list-style-type: none"> 1. Air in system. 2. Low oil level. 3. Clogged internal suction screen. 	<ol style="list-style-type: none"> 1. See section III C for bleeding procedure. 2. Fill reservoir to 13mm below top plate with correct oil. 3. See section V for cleaning procedure.
Pump Runs, But Will Not Pump Oil	<ol style="list-style-type: none"> 1. Defective control valve. 2. Quick coupling not fully engaged or damaged. 3. Pressure relief valve out of adjustment. 	<ol style="list-style-type: none"> 2. Trouble-shoot separately. 3. Fully engage couplings or replace as necessary. 4. Consult factory.
Pump Runs, Cylinders Extend/Retract, But Pump Will Not Build Pressure	<ol style="list-style-type: none"> 1. Excessive leak in hydraulic circuit. 2. With double-acting circuit, defective seal(s) allowing high pressure fluid leakage to low pressure side. 3. Pressure relief valve out of adjustment. 	<ol style="list-style-type: none"> 1. Find and repair leak. 2. Trouble-shoot separately. 3. Consult factory.

SECTION VI

TROUBLE SHOOTING (continued)

Symptom	Cause	Solution
Pressure Does Not Hold (Pump Starts And Stops Frequently)	<ol style="list-style-type: none"> 1. Damaged seal(s). 2. System equipped with spool type valve. 3. Oil leaking past check valve in manifold. 4. Pressure relief valve set too close to pressure switch point. 	<ol style="list-style-type: none"> 1. Isolate leaking device, and repair/replace. 2. Replace spool valve with poppet or shear type valve. 3. Remove, inspect and clean/replace valve seat, see section V. 4. Consult factory.
Motor Does Not Stop Automatically	<ol style="list-style-type: none"> 1. Incorrect pressure switch setting. 2. Pressure switch wiring faulty. 3. Pressure switch faulty. 	<ol style="list-style-type: none"> 1. Re-set pressure switch, see section III B. 2. Check switch wires. 3. Replace pressure switch.

If the procedures listed above do not remedy symptoms, contact factory at +1-913-365-1045.

SECTION VII

WARRANTY AND RETURN INFORMATION

WARRANTY

Vektek LLC warrants each VektorFlo® product to the original purchaser unless end user assignment is made at the time of purchase. Each device is warranted against defects in workmanship and materials for one year from the date of delivery.

This warranty is limited to the repair or replacement of any part or parts which are found by Vektek to be defective and does not cover ordinary wear and tear, abuse, misapplication, overloading, excessive flow rates, altered products, contamination or the use of improper fluids.

This warranty is the only warranty covering VektorFlo products. There are no other warranties covering VektorFlo products, either expressed or implied.

Vektek, Inc. specifically disclaims any warranty of merchantability or fitness for a particular purpose.

When the question of warranty arises, the user must contact the factory for permission to return the merchandise. All returned merchandise must be addressed to a Return Authorization number and shipped to the address indicated on the RA.

RETURNS

All returns are subject to a progressive restocking fee. There is a \$25.00 (us dollar) minimum restocking fee on any return. All returns must be pre-authorized, please call for Return Authorization number. Any return not sent to a specific RA number will be treated as scrap. Transportation is to be prepaid and the evidence of delivery date furnished.

Safety Data Sheet

According to OSHA HCS 2012 (29 CFR 1910.1200)

**SECTION 1: Identification**

Product Identifier	Megaflow® AW Hydraulic Oil
Other means of identification	Phillips 66 Megaflow® AW Hydraulic Oil 22 Phillips 66 Megaflow® AW Hydraulic Oil 32 Phillips 66 Megaflow® AW Hydraulic Oil 46 Phillips 66 Megaflow® AW Hydraulic Oil 68 Phillips 66 Megaflow® AW Hydraulic Oil 100 Phillips 66 Megaflow® AW Hydraulic Oil 150 Phillips 66 Megaflow® AW Hydraulic Oil 220 Phillips 66 Megaflow® AW Hydraulic Oil 320
SDS Number	LBPH814637
Relevant identified uses	Hydraulic Fluid
Uses advised against	All others
24 Hour Emergency Phone Number	CHEMTREC 1-800-424-9300 CHEMTREC Mexico 01-800-681-9531

Manufacturer/Supplier	SDS Information	Customer Service
Phillips 66 Lubricants P.O. Box 4428 Houston, TX 77210	Phone: 800-762-0942 Email: SDS@P66.com URL:www.Phillips66.com	U.S.: 800-368-7128 or International: 1-832-765-2500 Technical Information 1-877-445-9198

SECTION 2: Hazard identification

Classified Hazards	Hazards Not Otherwise Classified (HNOC)
This material is not hazardous under the criteria of the Federal OSHA Hazard Communication Standard 29CFR1910.1200.	PHNOC: None known HHNOC: None known

Label Elements

No classified hazards

SECTION 3: Composition/information on ingredients

Chemical Name	CASRN	Concentration ¹
Distillates, petroleum, hydrotreated heavy paraffinic	64742-54-7	>99

¹ All concentrations are percent by weight unless ingredient is a gas. Gas concentrations are in percent by volume.**SECTION 4: First aid measures****Eye Contact:** If irritation or redness develops from exposure, flush eyes with clean water. If symptoms persist, seek medical attention.**Skin Contact:** First aid is not normally required. However, it is good practice to wash any chemical from the skin. If product is injected into or under the skin, or into any part of the body, regardless of the appearance of the wound or its size, the individual should be evaluated immediately by a physician. (see Note to Physician)**Inhalation:** First aid is not normally required. If breathing difficulties develop, move victim away from source of exposure and into fresh air in a position comfortable for breathing. Seek immediate medical attention.**Ingestion:** First aid is not normally required; however, if swallowed and symptoms develop, seek medical attention.

Most important symptoms and effects, both acute and delayed: Inhalation of oil mists or vapors generated at elevated temperatures may cause respiratory irritation. Accidental ingestion can result in minor irritation of the digestive tract, nausea and diarrhea.

Notes to Physician: Acute aspirations of large amounts of oil-laden material may produce a serious aspiration pneumonia. Patients who aspirate these oils should be followed for the development of long-term sequelae. Inhalation exposure to oil mists below current workplace exposure limits is unlikely to cause pulmonary abnormalities. When using high-pressure equipment, injection of product under the skin can occur. In this case, the casualty should be sent immediately to the hospital. Do not wait for symptoms to develop. High-pressure hydrocarbon injection injuries may produce substantial necrosis of underlying tissue despite an innocuous appearing external wound. These injuries often require extensive emergency surgical debridement and all injuries should be evaluated by a specialist in order to assess the extent of injury. Early surgical treatment within the first few hours may significantly reduce the ultimate extent of injury.

SECTION 5: Firefighting measures

NFPA 704 Hazard Class

Health: 0 Flammability: 1 Instability: 0



0 (Minimal)
1 (Slight)
2 (Moderate)
3 (Serious)
4 (Severe)

Extinguishing Media: Dry chemical, carbon dioxide, foam, or water spray is recommended. Water or foam may cause frothing of materials heated above 212°F / 100°C. Carbon dioxide can displace oxygen. Use caution when applying carbon dioxide in confined spaces. Simultaneous use of foam and water on the same surface is to be avoided as water destroys the foam.

Specific hazards arising from the chemical

Unusual Fire & Explosion Hazards: This material may burn, but will not ignite readily. If container is not properly cooled, it can rupture in the heat of a fire.

Hazardous Combustion Products: Combustion may yield smoke, carbon monoxide, and other products of incomplete combustion. Oxides of sulfur, nitrogen or phosphorus may also be formed.

Special protective actions for firefighters: For fires beyond the initial stage, emergency responders in the immediate hazard area should wear protective clothing. When the potential chemical hazard is unknown, in enclosed or confined spaces, a self contained breathing apparatus should be worn. In addition, wear other appropriate protective equipment as conditions warrant (see Section 8).

Isolate the hazard area and deny entry to unnecessary and unprotected personnel Stop spill/release if it can be done safely. Move undamaged containers from immediate hazard area if it can be done safely Water spray may be useful in minimizing or dispersing vapors and to protect personnel. Cool equipment exposed to fire with water, if it can be done safely. Avoid spreading burning liquid with water used for cooling purposes.

See Section 9 for Flammable Properties including Flash Point and Flammable (Explosive) Limits

SECTION 6: Accidental release measures

Personal precautions, protective equipment and emergency procedures: This material may burn, but will not ignite readily. Keep all sources of ignition away from spill/release. Stay upwind and away from spill/release. Avoid direct contact with material. For large spillages, notify persons down wind of the spill/release, isolate immediate hazard area and keep unauthorized personnel out. Wear appropriate protective equipment, including respiratory protection, as conditions warrant (see Section 8). See Sections 2 and 7 for additional information on hazards and precautionary measures.

Environmental Precautions: Stop and contain spill/release if it can be done safely. Prevent spilled material from entering sewers, storm drains, other unauthorized drainage systems, and natural waterways. Use water sparingly to minimize environmental contamination and reduce disposal requirements. If spill occurs on water notify appropriate authorities and advise shipping of any hazard. Spills into or upon navigable waters, the contiguous zone, or adjoining shorelines that cause a sheen or discoloration on the surface of the water, may require notification of the National Response Center (phone number 800-424-8802).

Methods and material for containment and cleaning up: Notify relevant authorities in accordance with all applicable regulations. Immediate cleanup of any spill is recommended. Dike far ahead of spill for later recovery or disposal. Absorb spill with inert material such as sand or vermiculite, and place in suitable container for disposal. If spilled on water remove with appropriate methods (e.g. skimming, booms or absorbents). In case of soil contamination, remove contaminated soil for remediation or disposal, in accordance with local regulations.

Recommended measures are based on the most likely spillage scenarios for this material; however local conditions and regulations may influence or limit the choice of appropriate actions to be taken. See Section 13 for information on appropriate disposal.

SECTION 7: Handling and storage

Precautions for safe handling: Keep away from flames and hot surfaces. Wash thoroughly after handling. Use good personal hygiene practices and wear appropriate personal protective equipment (see section 8). Spills will produce very slippery surfaces. High pressure injection of hydrocarbon fuels, hydraulic oils or greases under the skin may have serious consequences even though no symptoms or injury may be apparent. This can happen accidentally when using high pressure equipment such as high pressure grease guns, fuel injection apparatus or from pinhole leaks in tubing of high pressure hydraulic oil equipment.

Do not enter confined spaces such as tanks or pits without following proper entry procedures such as ASTM D-4276 and 29CFR 1910.146. Do not wear contaminated clothing or shoes.

Conditions for safe storage: Keep container(s) tightly closed and properly labeled. Use and store this material in cool, dry, well-ventilated area away from heat and all sources of ignition. Store only in approved containers. Keep away from any incompatible material (see Section 10). Protect container(s) against physical damage.

"Empty" containers retain residue and may be dangerous. Do not pressurize, cut, weld, braze, solder, drill, grind, or expose such containers to heat, flame, sparks, or other sources of ignition. They may explode and cause injury or death. "Empty" drums should be completely drained, properly bunged, and promptly shipped to the supplier or a drum reconditioner. All containers should be disposed of in an environmentally safe manner and in accordance with governmental regulations. Before working on or in tanks which contain or have contained this material, refer to OSHA regulations, ANSI Z49.1, and other references pertaining to cleaning, repairing, welding, or other contemplated operations.

SECTION 8: Exposure controls/personal protection

Chemical Name	ACGIH	OSHA	Phillips 66
Distillates, petroleum, hydrotreated heavy paraffinic	---	---	TWA: 5 mg/m ³ STEL: 10 mg/m ³ as Oil Mist, if Generated

Note: State, local or other agencies or advisory groups may have established more stringent limits. Consult an industrial hygienist or similar professional, or your local agencies, for further information.

Engineering controls: If current ventilation practices are not adequate to maintain airborne concentrations below the established exposure limits, additional engineering controls may be required.

Eye/Face Protection: The use of eye/face protection is not normally required; however, good industrial hygiene practice suggests the use of eye protection that meets or exceeds ANSI Z.87.1 whenever working with chemicals.

Skin/Hand Protection: The use of skin protection is not normally required; however, good industrial hygiene practice suggests the use of gloves or other appropriate skin protection whenever working with chemicals. Suggested protective materials: Nitrile

Respiratory Protection: Where there is potential for airborne exposure above the exposure limit a NIOSH certified air purifying respirator equipped with R or P95 filters may be used.

A respiratory protection program that meets or is equivalent to OSHA 29 CFR 1910.134 and ANSI Z88.2 should be followed whenever workplace conditions warrant a respirator's use. Air purifying respirators provide limited protection and cannot be used in atmospheres that exceed the maximum use concentration (as directed by regulation or the manufacturer's instructions), in oxygen deficient (less than 19.5 percent oxygen) situations, or under conditions that are immediately dangerous to life and health (IDLH).

Suggestions provided in this section for exposure control and specific types of protective equipment are based on readily available information. Users should consult with the specific manufacturer to confirm the performance of their protective equipment. Specific situations may require consultation with industrial hygiene, safety, or engineering professionals.

SECTION 9: Physical and chemical properties

Note: Unless otherwise stated, values are determined at 20°C (68°F) and 760 mm Hg (1 atm). Data represent typical values and are not intended to be specifications.

Appearance: Amber, Transparent

Physical Form: Liquid

Odor: Petroleum

Odor Threshold: No data

pH: Not applicable

Vapor Density (air=1): >1

Upper Explosive Limits (vol % in air): No data

Lower Explosive Limits (vol % in air): No data

Evaporation Rate (nBuAc=1): No data

Particle Size: Not applicable

Percent Volatile: No data

Flammability (solid, gas): Not applicable

Solubility in Water: Negligible

Flash Point: > 302 °F / > 150 °C (ASTMD93)

Test Method: Pensky-Martens Closed Cup (PMCC), ASTM D93, EPA 1010

Initial Boiling Point/Range: No data

Vapor Pressure: <1 mm Hg

Partition Coefficient (n-octanol/water) (Kow): No data

Melting/Freezing Point: No data

Auto-ignition Temperature: No data

Decomposition Temperature: No data

Specific Gravity (water=1): 0.85-0.89 @ 60°F (15.6°C)

Bulk Density: No data

Viscosity: 4.0 - 25 cSt @ 100°C; 21 - 345 cSt @ 40°C

Pour Point: < 10 °F / < -12 °C

SECTION 10: Stability and reactivity

Reactivity: Not chemically reactive.

Chemical stability: Stable under normal ambient and anticipated conditions of use.

Possibility of hazardous reactions: Hazardous reactions not anticipated.

Conditions to avoid: Extended exposure to high temperatures can cause decomposition. Avoid all possible sources of ignition.

Incompatible materials: Avoid contact with strong oxidizing agents and strong reducing agents.

Hazardous decomposition products: Not anticipated under normal conditions of use.

SECTION 11: Toxicological information

Information on Toxicological Effects

Substance / Mixture

Acute Toxicity	Hazard	Additional Information	LC50/LD50 Data
Inhalation	Unlikely to be harmful		>5 mg/L (mist, estimated)
Dermal	Unlikely to be harmful		> 2 g/kg (estimated)
Oral	Unlikely to be harmful		> 5 g/kg (estimated)

Aspiration Hazard: Not expected to be an aspiration hazard.

Skin Corrosion/Irritation: Not expected to be irritating.

Serious Eye Damage/Irritation: Not expected to be irritating.

Skin Sensitization: No information available on the mixture, however none of the components have been classified for skin sensitization (or are below the concentration threshold for classification).

Respiratory Sensitization: No information available.

Specific Target Organ Toxicity (Single Exposure): No information available on the mixture, however none of the components have been classified for target organ toxicity (or are below the concentration threshold for classification).

Specific Target Organ Toxicity (Repeated Exposure): No information available on the mixture, however none of the components have been classified for target organ toxicity (or are below the concentration threshold for classification).

Carcinogenicity: No information available on the mixture, however none of the components have been classified for carcinogenicity (or are below the concentration threshold for classification).

Germ Cell Mutagenicity: No information available on the mixture, however none of the components have been classified for germ cell mutagenicity (or are below the concentration threshold for classification).

Reproductive Toxicity: No information available on the mixture, however none of the components have been classified for reproductive toxicity (or are below the concentration threshold for classification).

Information on Toxicological Effects of Components

Distillates, petroleum, hydrotreated heavy paraffinic

Carcinogenicity: This oil has been highly refined by a variety of processes to reduce aromatics and improve performance characteristics. It meets the IP-346 criteria of less than 3 percent PAH's and is not considered a carcinogen by the International Agency for Research on Cancer.

SECTION 12: Ecological information

Toxicity: All acute aquatic toxicity studies on samples of lubricant base oils show acute toxicity values greater than 100 mg/L for

GHS Classification: No classified hazards

invertebrates, algae and fish. These tests were carried out on water accommodated fractions and the results are consistent with the predicted aquatic toxicity of these substances based on their hydrocarbon compositions.

Persistence and Degradability: The hydrocarbons in this material are not readily biodegradable, but since they can be degraded by microorganisms, they are regarded as inherently biodegradable.

Bioaccumulative Potential: Log Kow values measured for the hydrocarbon components of this material are greater than 5.3, and therefore regarded as having the potential to bioaccumulate. In practice, metabolic processes may reduce bioconcentration.

Mobility in Soil: Volatilization to air is not expected to be a significant fate process due to the low vapor pressure of this material. In water, base oils will float and spread over the surface at a rate dependent upon viscosity. There will be significant removal of hydrocarbons from the water by sediment adsorption. In soil and sediment, hydrocarbon components will show low mobility with adsorption to sediments being the predominant physical process. The main fate process is expected to be slow biodegradation of the hydrocarbon constituents in soil and sediment.

Other adverse effects: None anticipated.

SECTION 13: Disposal considerations

The generator of a waste is always responsible for making proper hazardous waste determinations and needs to consider state and local requirements in addition to federal regulations. This material, if discarded as produced, would not be a federally regulated RCRA "listed" hazardous waste and is not believed to exhibit characteristics of hazardous waste. See Sections 7 and 8 for information on handling, storage and personal protection and Section 9 for physical/chemical properties. It is possible that the material as produced contains constituents which are not required to be listed in the SDS but could affect the hazardous waste determination. Additionally, use which results in chemical or physical change of this material could subject it to regulation as a hazardous waste. This material under most intended uses would become "Used Oil" due to contamination by physical or chemical impurities. Whenever possible, Recycle used oil in accordance with applicable federal and state or local regulations. Container contents should be completely used and containers should be emptied prior to discard.

SECTION 14: Transport information

U.S. Department of Transportation (DOT)

UN Number: Not regulated

UN proper shipping name: None

Transport hazard class(es): None

Packing Group: None

Environmental Hazards: This product does not meet the DOT/UN/IMDG/IMO criteria of a marine pollutant

Special precautions for user: If shipped by land in a packaging having a capacity of 3,500 gallons or more, the provisions of 49 CFR, Part 130 apply. (Contains oil)

Transport in bulk according to Annex II of MARPOL 73/78 and the IBC Code: Not applicable

SECTION 15: Regulatory information

CERCLA/SARA - Section 302 Extremely Hazardous Substances and TPQs (in pounds):

This material does not contain any chemicals subject to the reporting requirements of SARA 302 and 40 CFR 372.

CERCLA/SARA - Section 311/312 (Title III Hazard

Categories) Acute Health Hazard:	No
Chronic Health Hazard:	No
Fire Hazard:	No
Pressure Hazard:	No
Reactive Hazard:	No

CERCLA/SARA - Section 313 and 40 CFR 372:

This material does not contain any chemicals subject to the reporting requirements of SARA 313 and 40 CFR 372.

EPA (CERCLA) Reportable Quantity (in pounds):

This material does not contain any chemicals with CERCLA Reportable Quantities.

California Proposition 65:

This material does not contain any chemicals which are known to the State of California to cause cancer, birth defects or other reproductive harm at concentrations that trigger the warning requirements of California Proposition 65.

International Hazard Classification

Canada:

This product has been classified in accordance with the hazard criteria of the Hazardous Products Regulations (SOR/2015-17) and the SDS contains all the information required by the Regulations.

International Inventories

All components are either listed on the US TSCA Inventory, or are not regulated under TSCA. All components are either on the DSL, or are exempt from DSL listing requirements.

U.S. Export Control Classification Number: EAR99

SECTION 16: Other information

Issue Date:	Previous Issue Date:	SDS Number	Status:
28-Jun-2016	23-Jun-2016	LBPH814637	FINAL

Revised Sections or Basis for Revision: New SDS

Guide to Abbreviations:

ACGIH = American Conference of Governmental Industrial Hygienists; CASRN = Chemical Abstracts Service Registry Number; CEILING = Ceiling Limit (15 minutes); CERCLA = The Comprehensive Environmental Response, Compensation, and Liability Act; EPA = Environmental Protection Agency; GHS = Globally Harmonized System; IARC = International Agency for Research on Cancer; INSHT = National Institute for Health and Safety at Work; IOPC = International Oil Pollution Compensation; LEL = Lower Explosive Limit; NE = Not Established; NFPA = National Fire Protection Association; NTP = National Toxicology Program; OSHA = Occupational Safety and Health Administration; PEL = Permissible Exposure Limit (OSHA); SARA = Superfund Amendments and Reauthorization Act; STEL = Short Term Exposure Limit (15 minutes); TLV = Threshold Limit Value (ACGIH); TWA = Time Weighted Average (8 hours); UEL = Upper Explosive Limit; WHMIS = Worker Hazardous Materials Information System (Canada)

Disclaimer of Expressed and implied Warranties:

The information presented in this Safety Data Sheet is based on data believed to be accurate as of the date this Safety Data Sheet was prepared. HOWEVER, NO WARRANTY OF MERCHANTABILITY, FITNESS FOR ANY PARTICULAR PURPOSE, OR ANY OTHER WARRANTY IS EXPRESSED OR IS TO BE IMPLIED REGARDING THE ACCURACY OR COMPLETENESS OF THE INFORMATION PROVIDED ABOVE, THE RESULTS TO BE OBTAINED FROM THE USE OF THIS INFORMATION OR THE PRODUCT, THE SAFETY OF THIS PRODUCT, OR THE HAZARDS RELATED TO ITS USE. No responsibility is assumed for any damage or injury resulting from abnormal use or from any failure to adhere to recommended practices. The information provided above, and the product, are furnished on the condition that the person receiving them shall make their own determination as to the suitability of the product for their particular purpose and on the condition that they assume the risk of their use. In addition, no authorization is given nor implied to practice any patented invention without a license.

SECTION IX

Vekttek LLC 1334 East Sixth Ave. P.O. Box 625 Emporia, Ks. 66801 U.S.A.	Instruction Sheet	IS-	7074
		REV:	B
		ECN:	1731
		DRAWN BY/DATE:	RATZLAFF 7-18-02
		APPR/DATE:	R. Hausler 8-8-02
Title Operating Instructions: Machine to Pump Control Wiring			

FAILURE TO FOLLOW INSTRUCTIONS WILL CAUSE VALVE FAILURE AND VOID WARRANTY.

1. Read and understand this document in its entirety.
2. This pump is an on demand pump. This wiring controls the valve, not the motor. The motor is controlled by the power switch, pressure switch, and float switch.
3. No internal wiring required.
4. Disconnect power to pump.
5. Remove pendant supplied with pump and store for future use.
6. Connect the "machine to pump control cable" to the "pump control box".
7. Valves are actuated by making contact between the red common wire and either white or black valve solenoid wire. The following color codes are listed below.

4/3 VALVE:

RED: COMMON (-24VDC)

WHITE: SOLENOID A CONTROL (+24VDC)

BLACK: SOLENOID B CONTROL (+24VDC)

GREEN: GROUND

3/2 VALVE:

RED: COMMON (-24VDC)

WHITE: SOLENOID A CONTROL (+24VDC)

BLACK: UNUSED (+24VDC)

GREEN: GROUND

8. Connect cable to controller following color codes above.
9. Connect power to pump.
10. Check for proper valve function.
11. If any instructions are not clear, contact factory at 1-800-992-0236.

Vekttek, Inc. 1334 East Sixth Ave. P.O. Box 625 Emporia, Ks. 66801 U.S.A.	Instruction Sheet	IS-	7074	
		REV:	B	
		ECN:	1731	
		DRAWN BY/DATE:	RATZLAFF	7-18-02
		APPR/DATE:	R. Hausler	8-8-02
Title Operating Instructions: Machine to Pump Control Wiring				

FAILURE TO FOLLOW INSTRUCTIONS WILL CAUSE VALVE FAILURE AND VOID WARRANTY.

1. Read and understand this document in its entirety.
2. This pump is an on demand pump. This wiring controls the valve, not the motor. The motor is controlled by the power switch, pressure switch, and float switch.
3. No internal wiring required.
4. Disconnect power to pump.
5. Remove pendant supplied with pump and store for future use.
6. Connect the “machine to pump control cable” to the “pump control box”.
7. Valves are actuated by making contact between the red common wire and either white or black valve solenoid wire. The following color codes are listed below.
 - 4/3 VALVE:
 - RED: COMMON (-24VDC)
 - WHITE: SOLENOID A CONTROL (+24VDC)
 - BLACK: SOLENOID B CONTROL (+24VDC)
 - GREEN: GROUND
 - 3/2 VALVE:
 - RED: COMMON (-24VDC)
 - WHITE: SOLENOID A CONTROL (+24VDC)
 - BLACK: UNUSED (+24VDC)
 - GREEN: GROUND
8. Connect cable to controller following color codes above.
9. Connect power to pump.
10. Check for proper valve function.
11. If any instructions are not clear, contact factory at 1-800-992-0236.